

ASSEMBLY INSTRUCTION FOR ACME FURNITURE

MODEL#21817EK-HB / #21818EK-FB / #21819EK-R

Thank you for purchasing this quality product. Be sure to check all packing material carefully for small parts which may have loose inside the carton during shipment. Separate, identify and count all parts and metal hardware. Compare with all parts list to be sure all parts are present. If any part(s) are missing or damaged, please contact your local furniture dealer. For efficient and speedy service, please indicate the model number and code letter of part(s) needed.

Do not fully tighten screw until fully assembled

COMPONENT PARTS		
DESCRIPTION	PART NAME	Q'TY (PCS)
(A)	HEADBOARD 	1
(B)	FOOTBOARD 	1
(C)	SIDE RAIL 	2
(D)	SLAT 	4
(E)	SLAT SUPPORT 	8

HARDWARE REQUIRED

NO	NAME	PART	QTY
1	Allen key		1pc
2	JCBC 35mm		8pcs
3	M6 Spring washer		8pcs
4	Screw 32mm		8pcs
5	Adjustable Leveller		8pcs

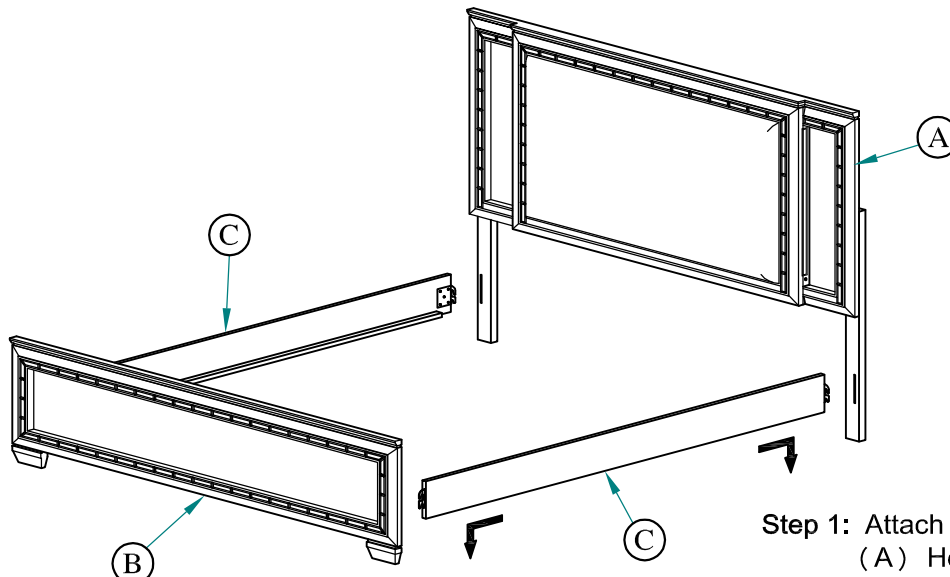
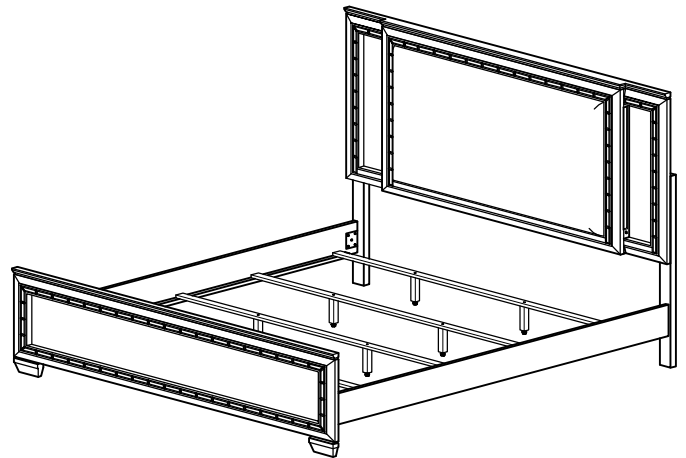

Step 1: Attach the (C) Side Rail to the (A) Headboard & (B) Footboard.

Step 2: Attach (E) Slat Support Leg to the bottom of Slat using (2) JCBC 35mm and (3) M6 Spring Washer. Attach the (5) Adjustable Leveller and adjust it to level the bed with the floor.

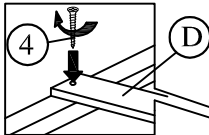
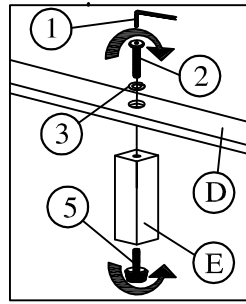

Step 3: Secure the (D) Slat using the (4) Screw 32mm provided.

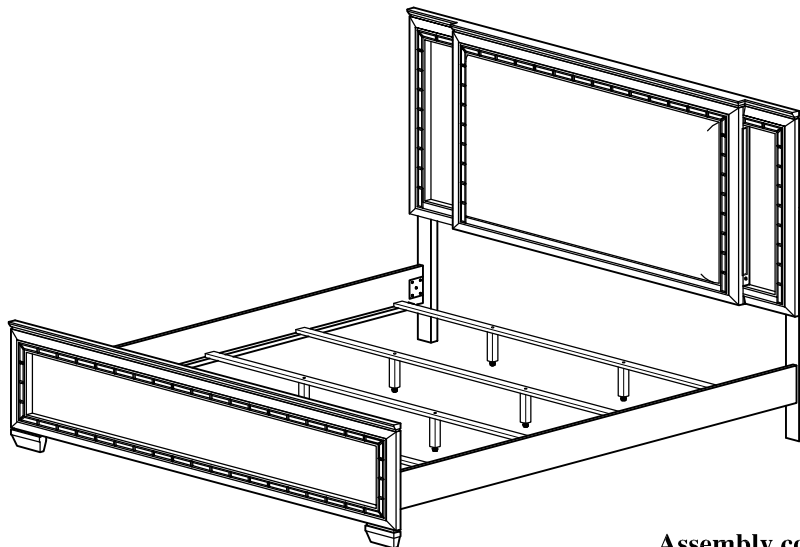
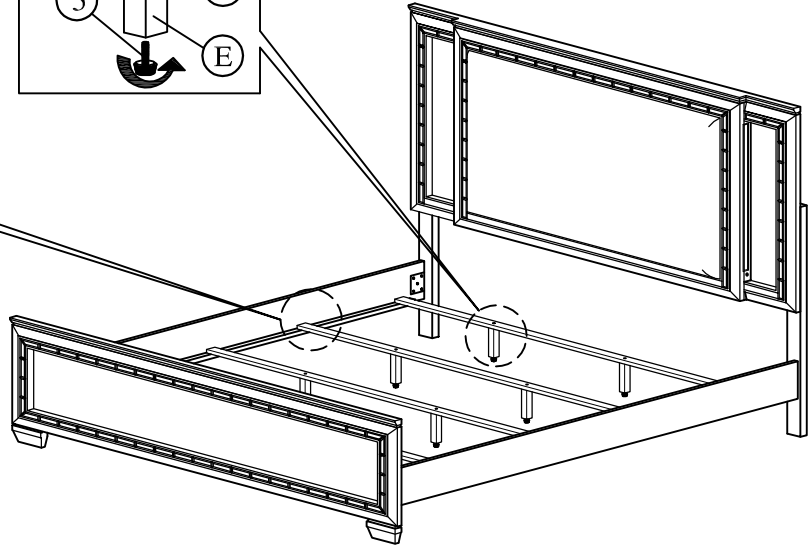

Assembly completed