

# ASSEMBLY INSTRUCTION FOR ACME FURNITURE

## MODEL#82472



Thank you for purchasing the quality product. Be sure to check all packing material carefully for small parts which may have come loose inside the carton during shipment. Separate, identify and count all parts and metal hardware. Compare with all parts list to be sure all parts are present. If any part(s) are missing or damaged, please contact your local furniture dealer. For efficient and speedy service, please indicate the model number and code letter of part(s) needed.

\*\*\* Do not fully tighten screws until fully assembled \*\*\*

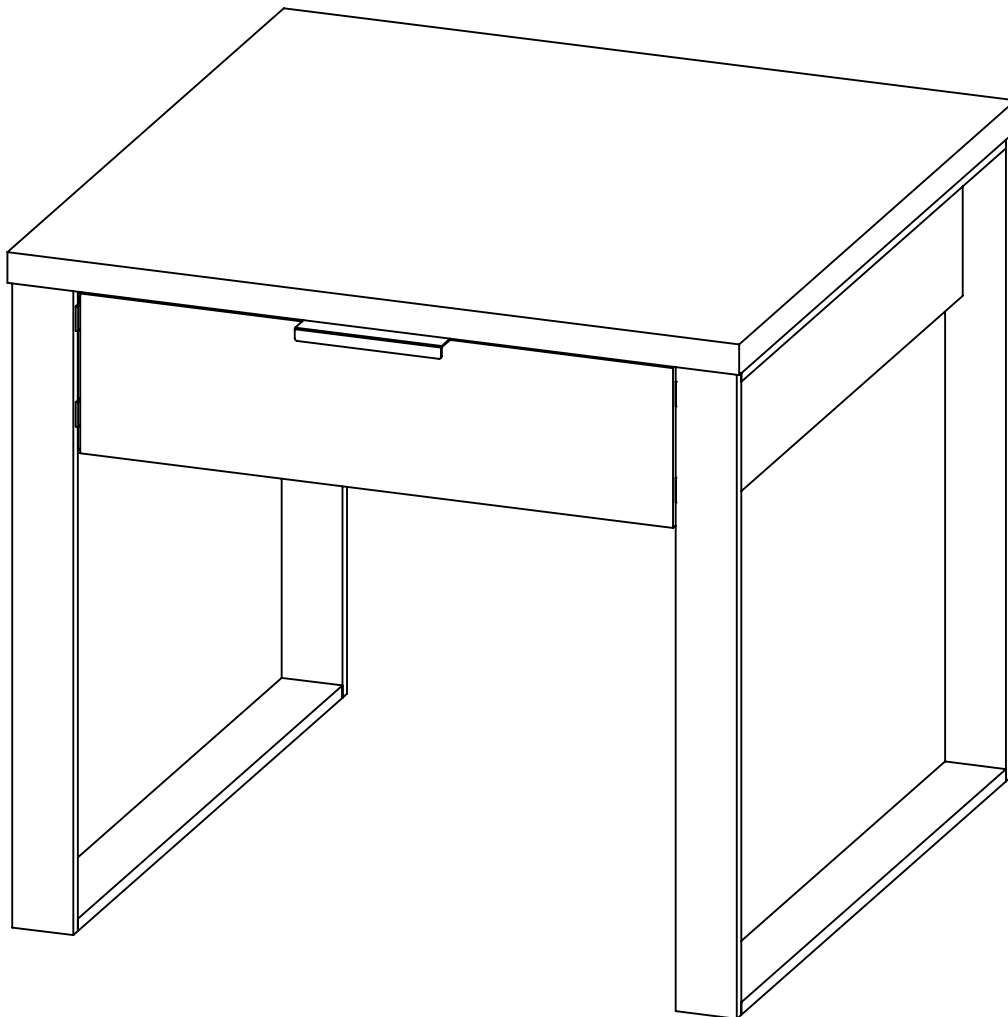



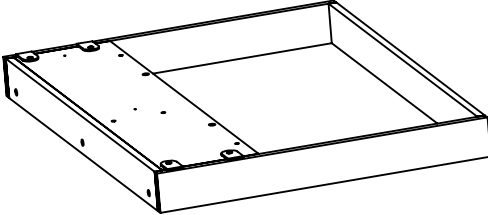
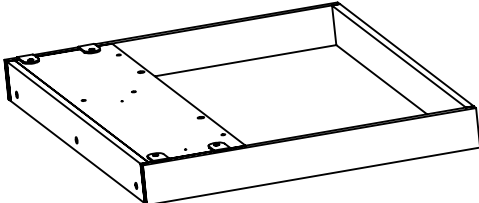
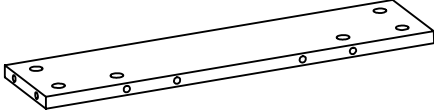
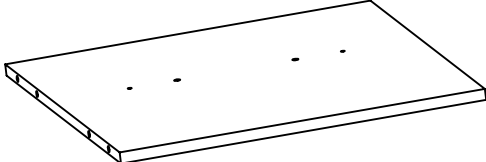
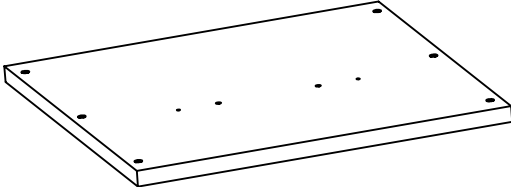
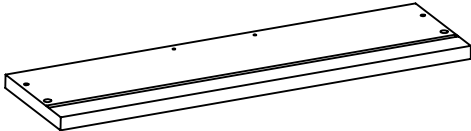

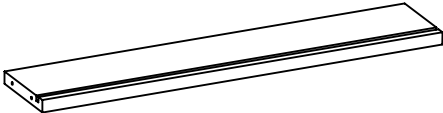
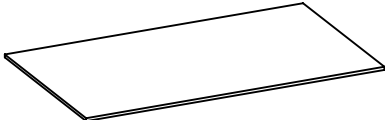



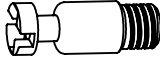

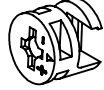
End table  
DIMENSIONS  
Length - 24"  
Width - 24"  
Height - 22"



# 82472 COMPONENT PARTS

DESCRIPTION	PART NAME	Q'TY(PCS)
①	Left side 	<b>1</b>
②	Right side 	<b>1</b>
③	Clapboard 	<b>1</b>
④	Bottom Plate 	<b>1</b>
⑤	Top Plate 	<b>1</b>
⑥	Drawer Head 	<b>1</b>
⑦	Drawer Left 	<b>1</b>
⑧	Drawer Right 	<b>1</b>
⑨	Drawer back 	<b>1</b>
⑩	Drawer Bottom 	<b>1</b>

# 82472 Hardware List

<p>Ⓐ  Cam bolt 7*39mm 12PCS</p>	<p>Ⓖ  Fixing screw 8.5*14mm 2PCS</p>
<p>Ⓑ  Cam lock 15*12mm 12PCS</p>	<p>Ⓗ  Iron handle 8.5*14mm 1PCS</p>
<p>Ⓒ  Wooden bolt (8*30mm) &amp; Glue 10+1PCS</p>	<p>Ⓘ  handle screw 9*14.5mm 2PCS</p>
<p>Ⓓ  Slide rail 17*310mm 2PCS</p>	<p>Ⓙ  Wood screw 8*38mm 2PCS</p>
<p>Ⓔ  Wood screw 6.5*12mm 4PCS</p>	<p>Ⓚ  Iron tube screen 10.7*50mm 4PCS</p>
<p>Ⓛ  Wood screw 8*31mm 4PCS</p>	<p>Ⓛ  Bolt (11*28mm) &amp; Allen Key 6+1PCS</p>

## Attention

Some number parts listed on the instruction sheet may not be in parts bag as they may already be assembled. Carefully check parts and packing materials prior to ordering replacements.

## Step:1

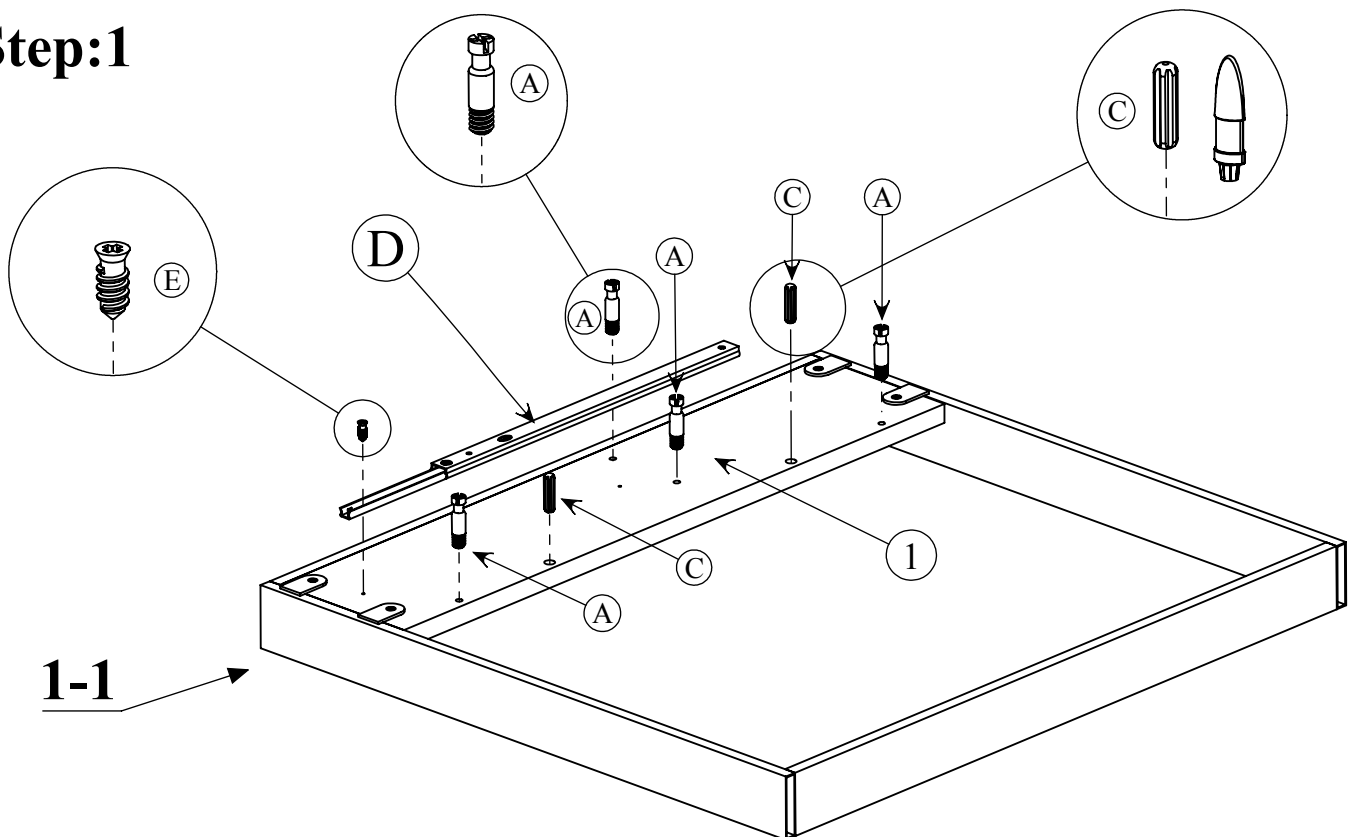

# Step:2

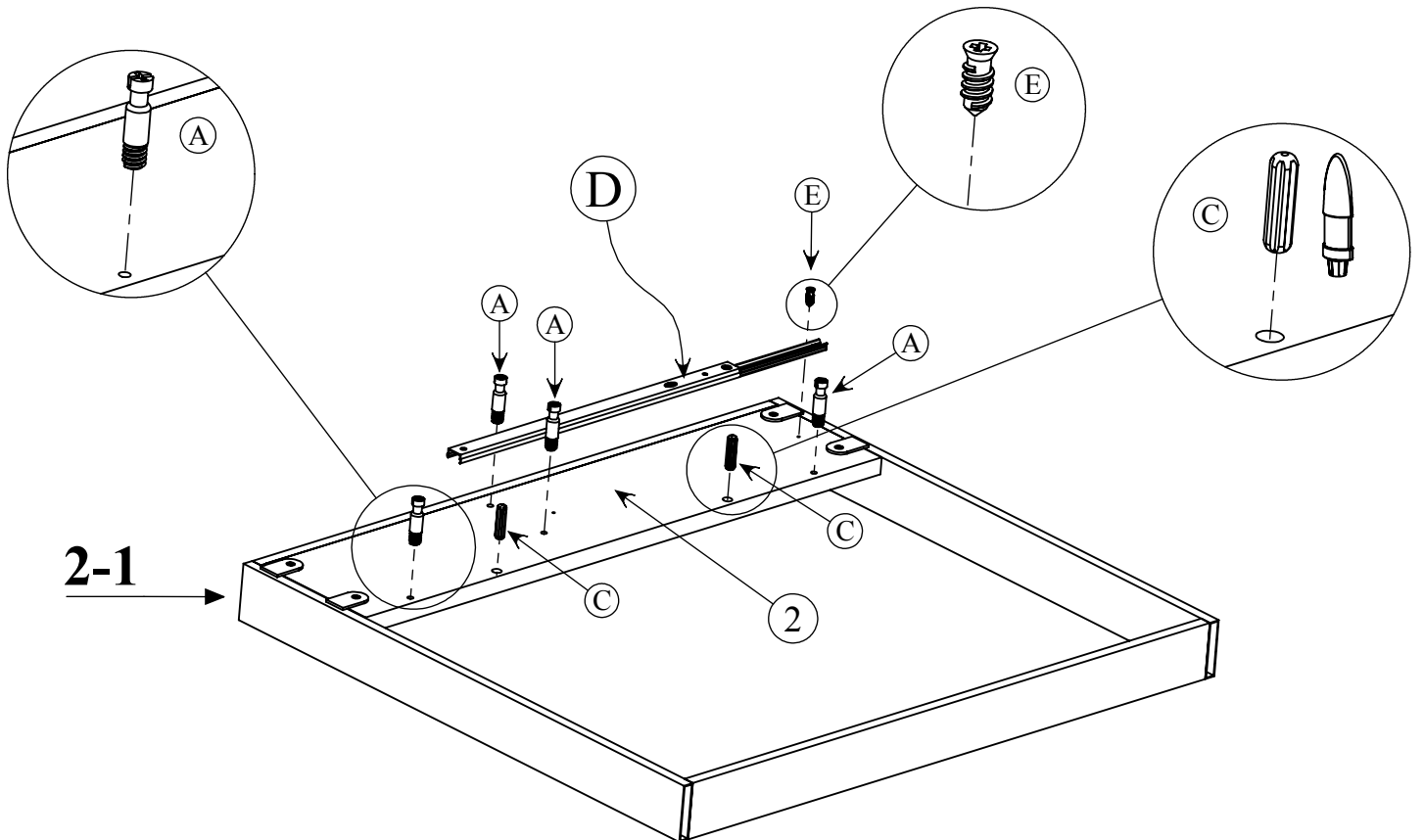
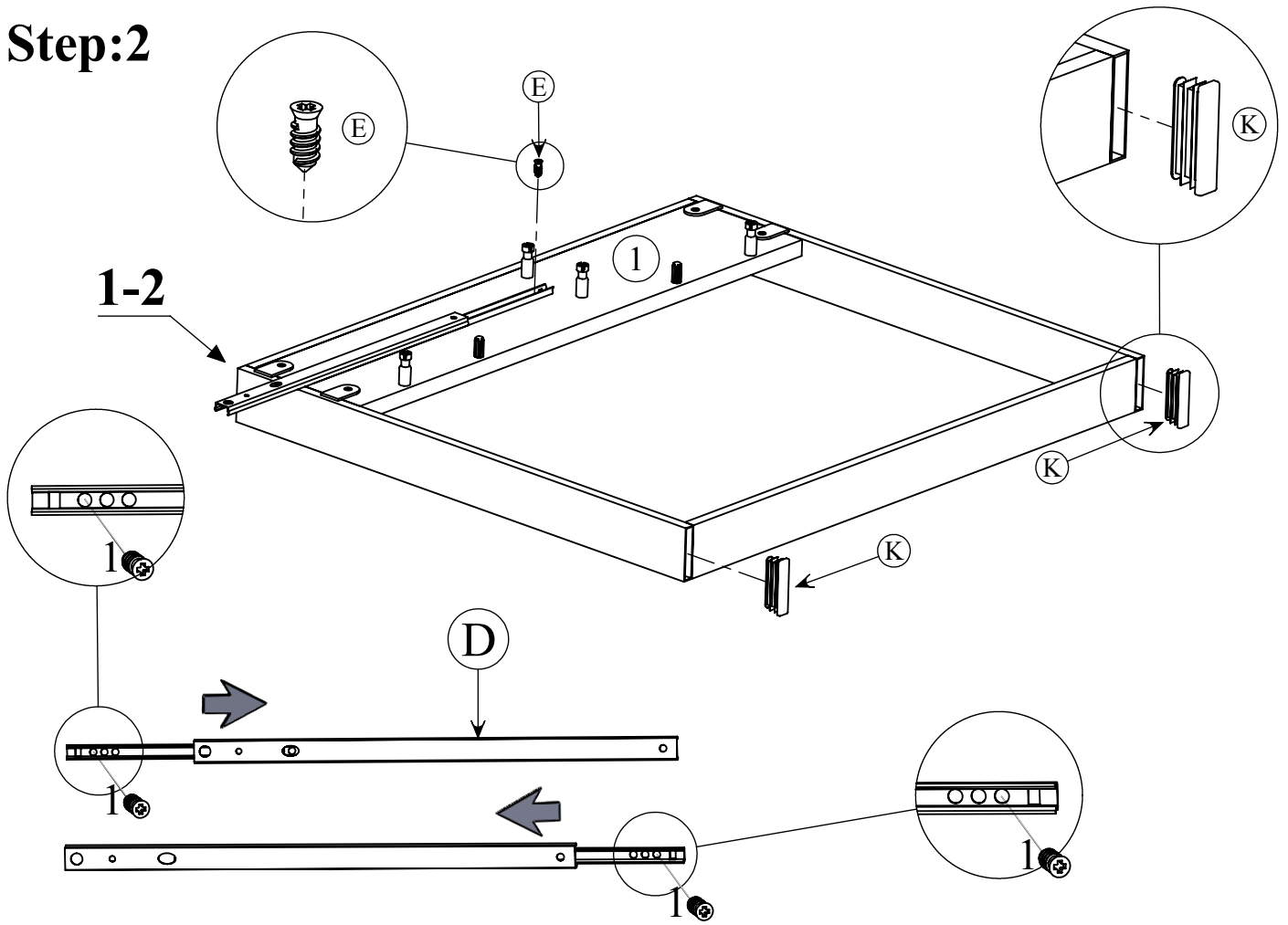

# Step:3

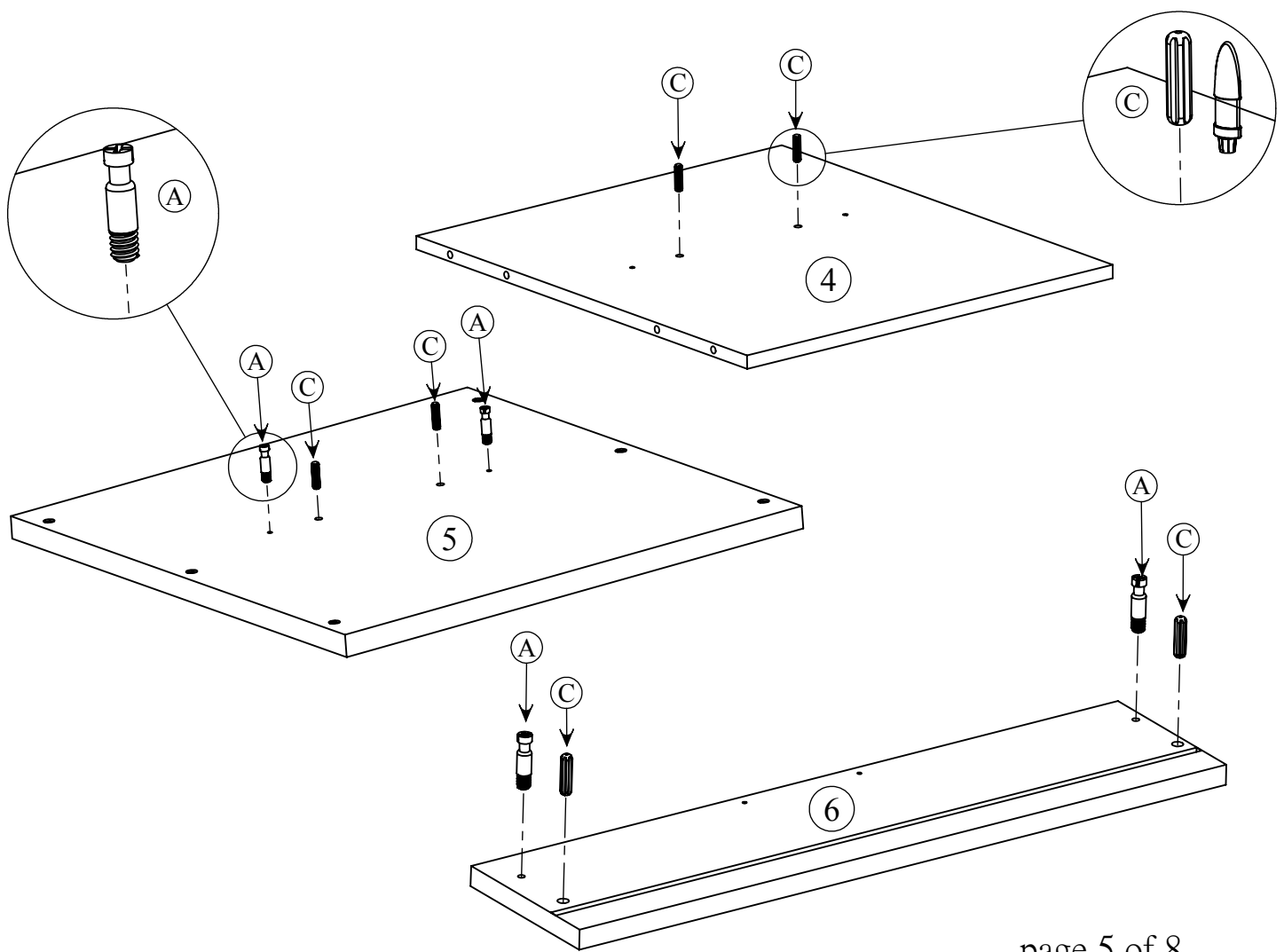
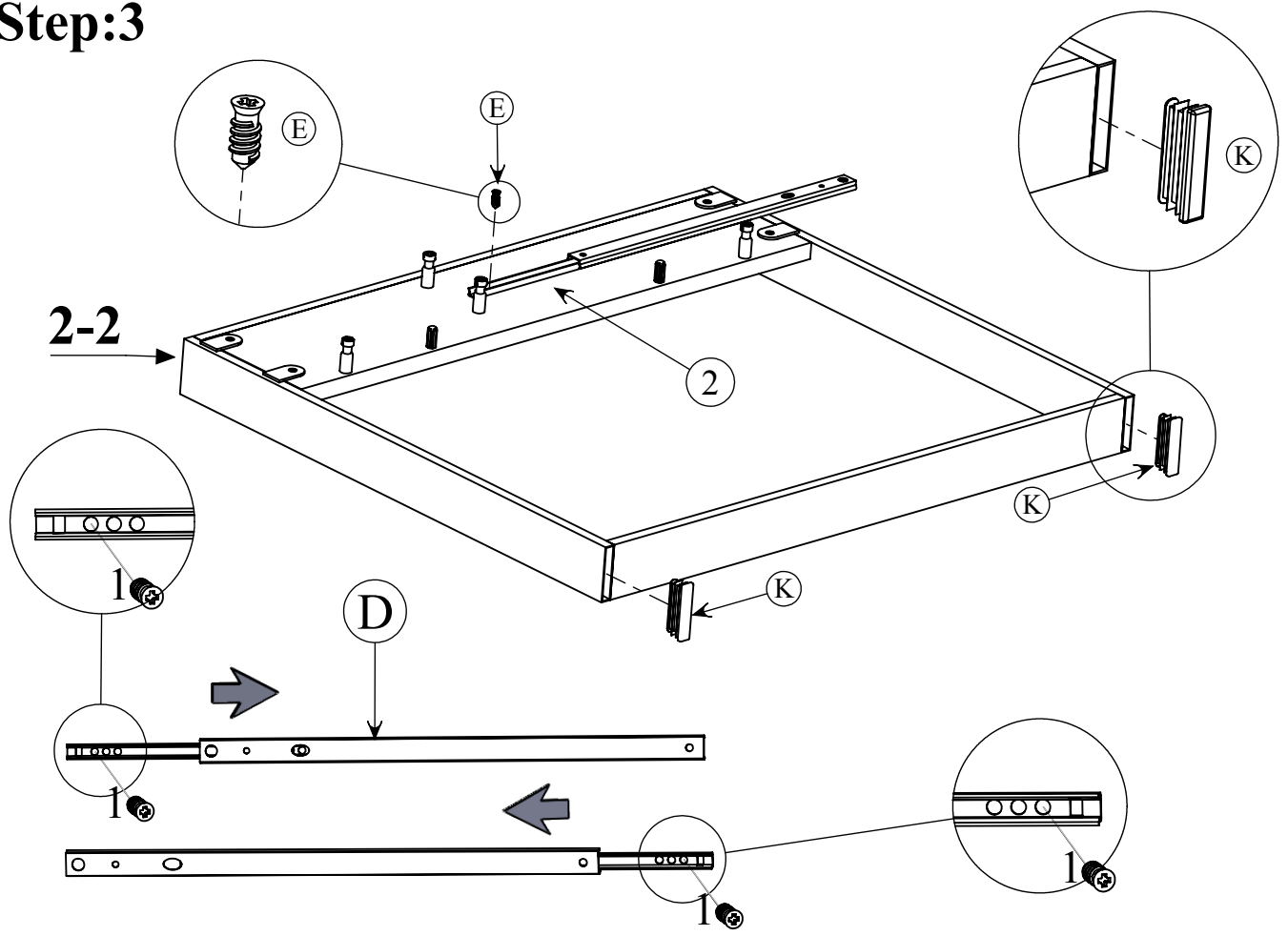

# Step:4

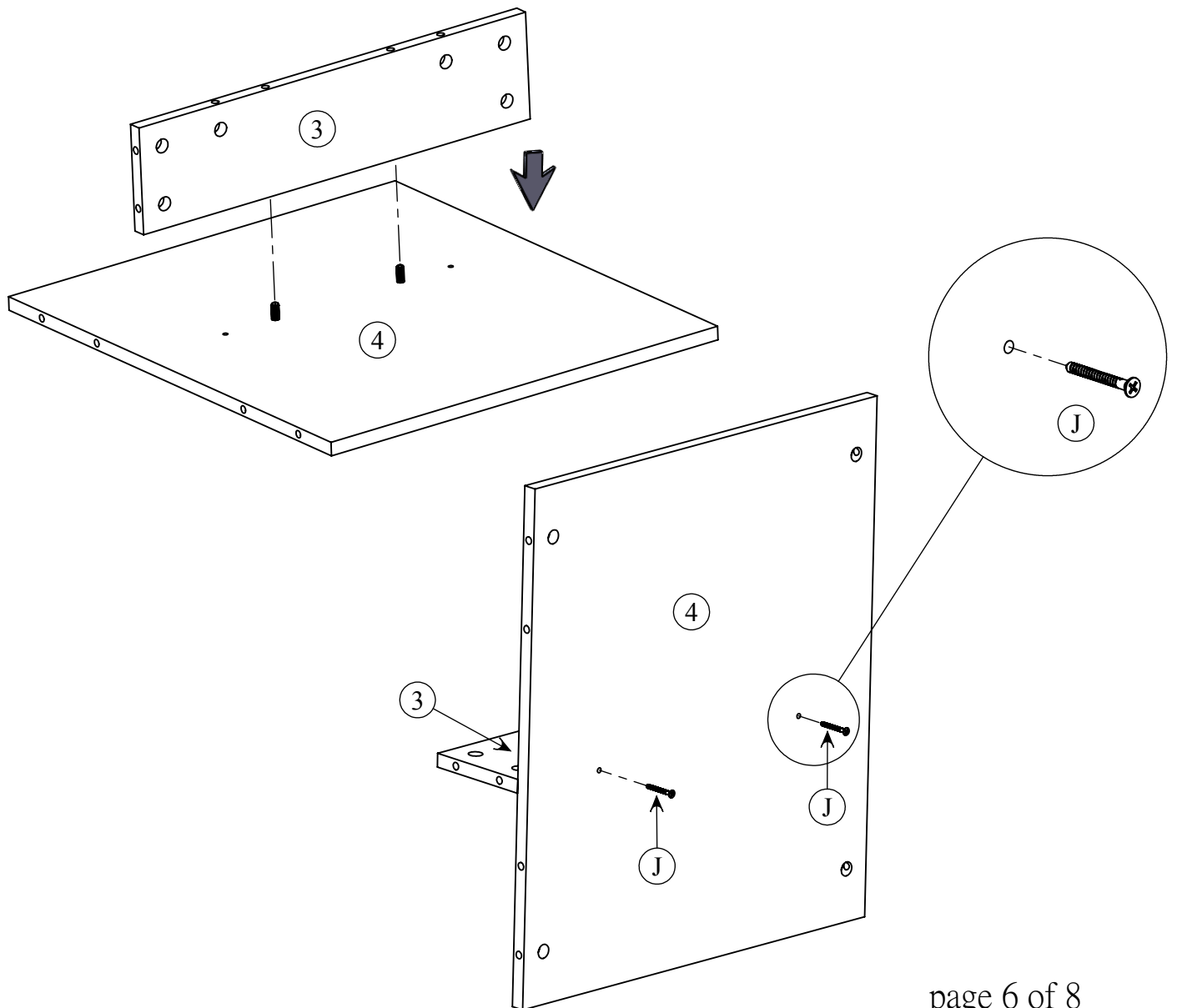
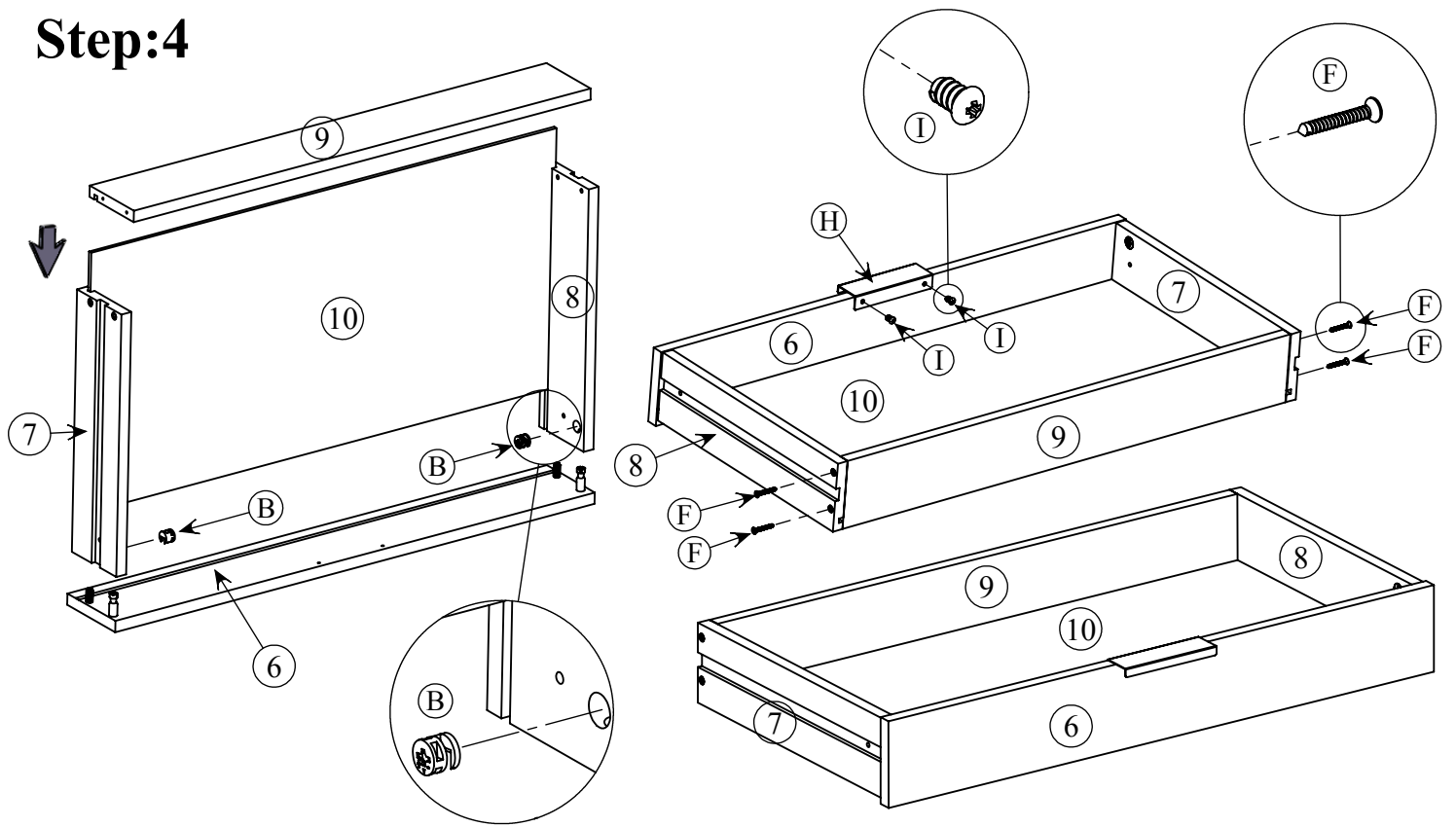

# Step:5

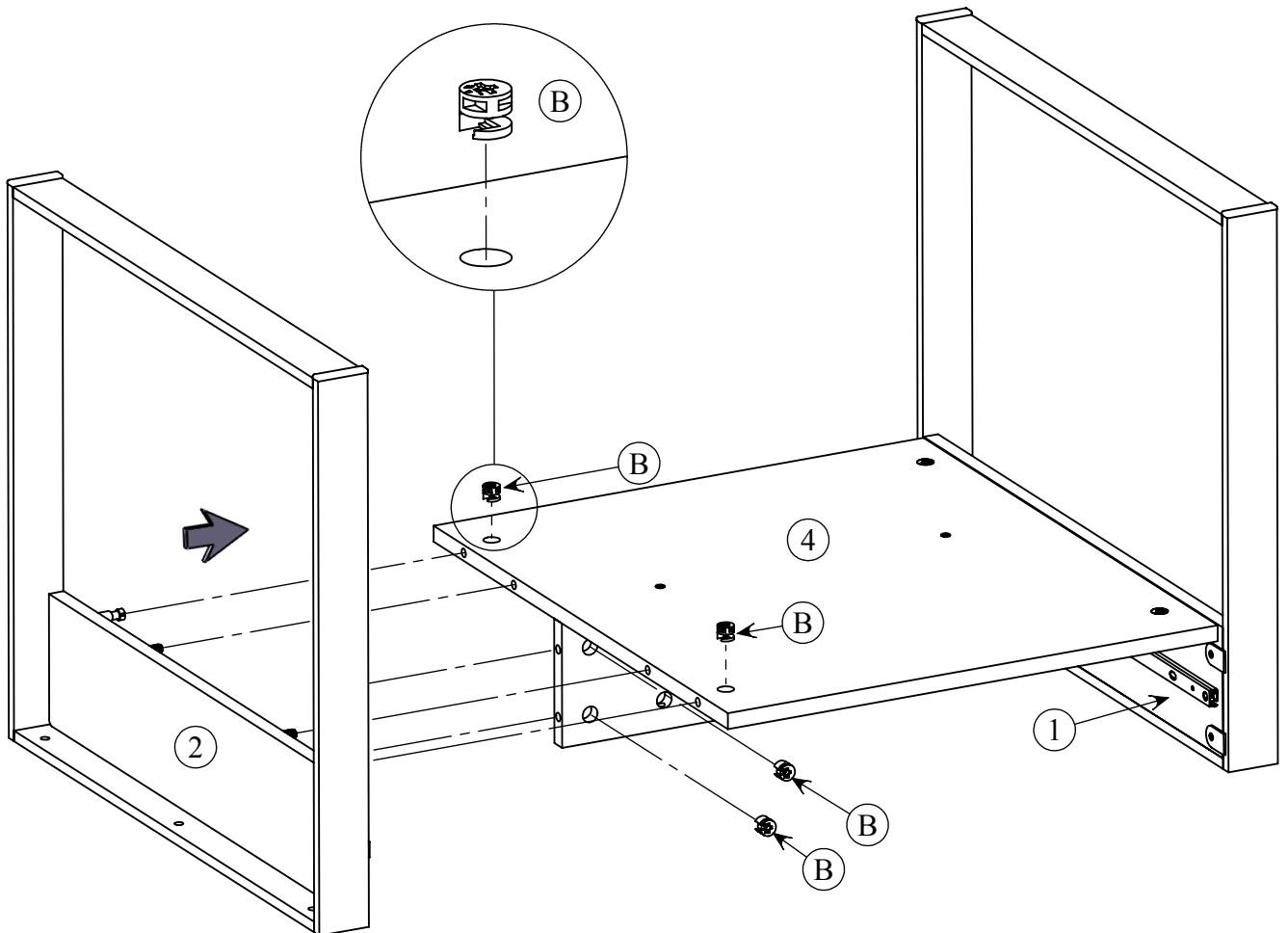
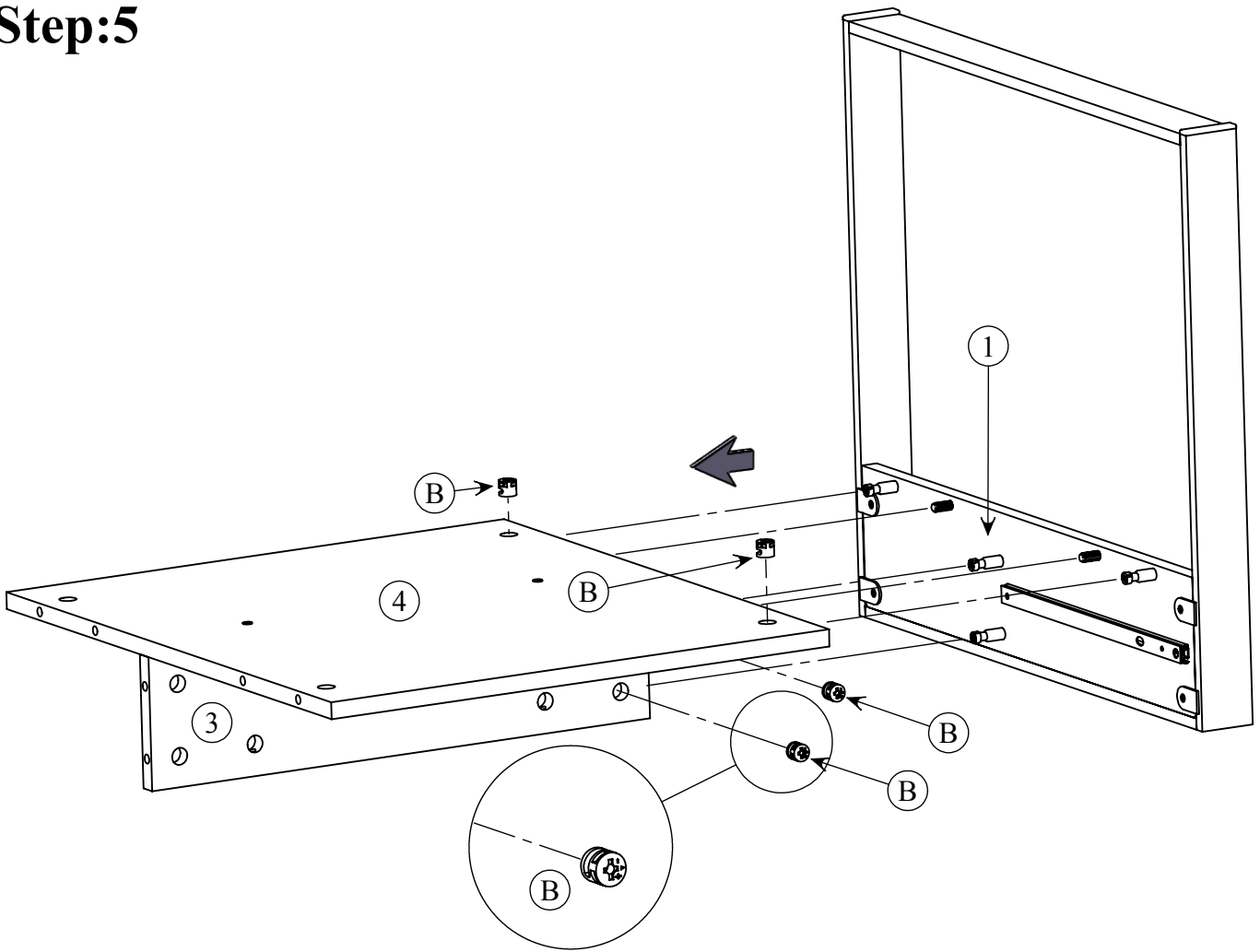

# Step:6

