

ASSEMBLY INSTRUCTION FOR ACME FURNITURE

MODEL#OF00991/OF00992

Thank you for purchasing the quality product. Be sure to check all packing material carefully for small parts which may have come loose inside the carton during shipment. Separate, identify and count all parts and metal hardware. Compare with all parts list to be sure all parts are present. If any part(s) are missing or damaged, please contact your local furniture dealer. For efficient and speedy service, please indicate the model number and code letter of part(s) needed.

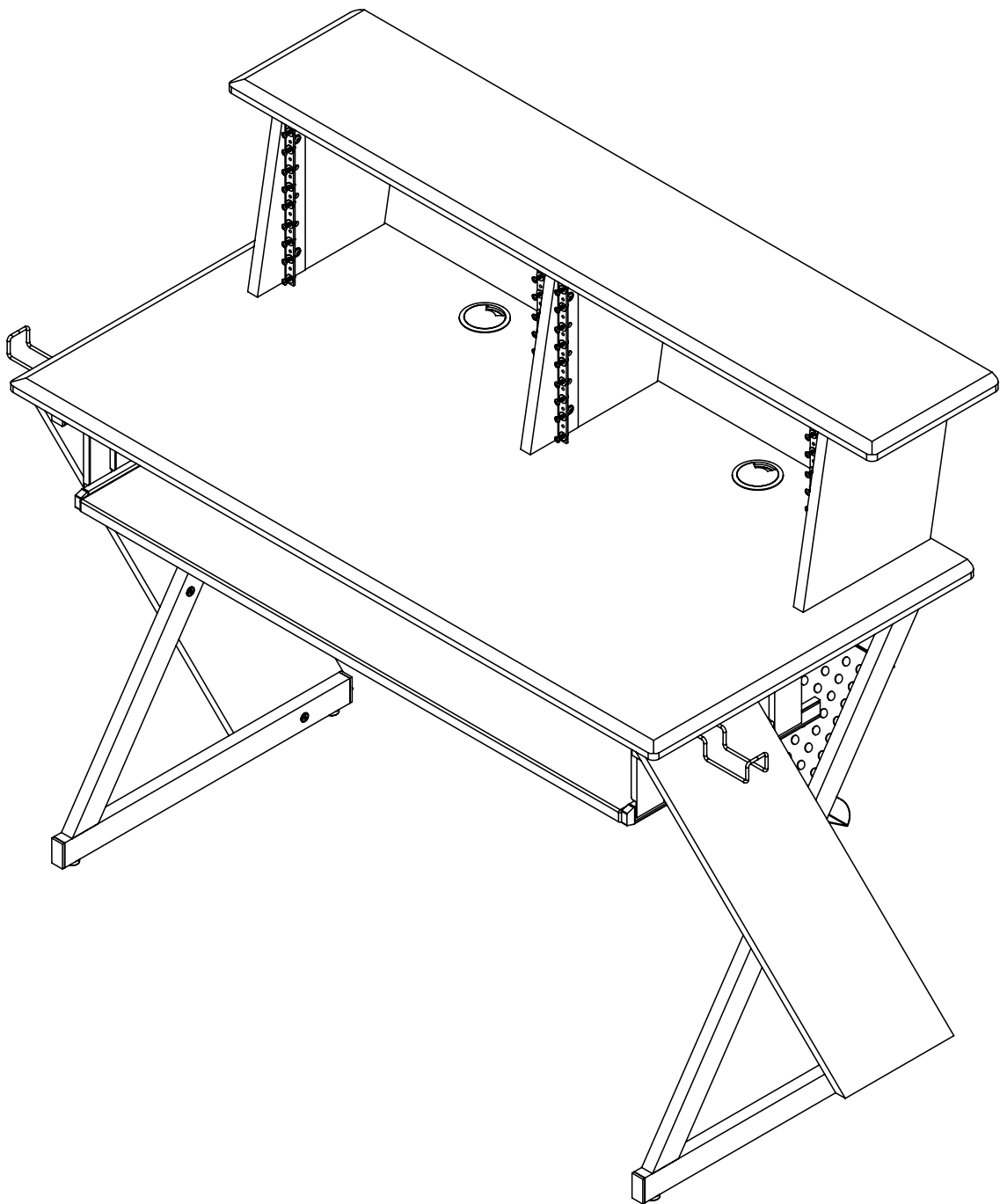



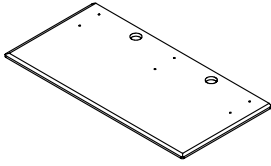
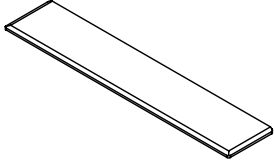
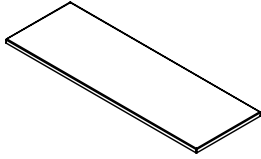
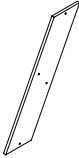
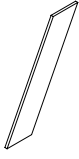
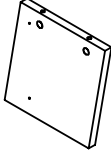
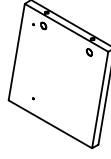
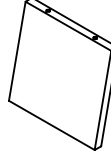
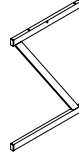
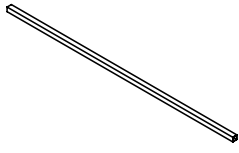

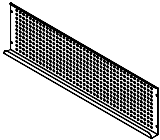
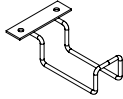
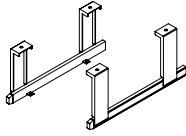
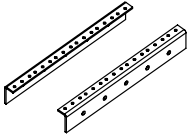



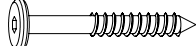

** Do not fully tighten screws until fully assembled **

COMPONENT PARTS		
DESCRIPTION	PART NAME	QTY(PCS)
①	DESKTOP 	1
②	TOP SHELF 	1
③	KEYBOARD SHELF 	1
④	RIGHT PANEL 	1
⑤	LEFT PANEL 	1
⑥	SMALL LEFT PANEL 	1
⑦	SMALL CENTRAL PANEL 	1
⑧	SMALL RIGHT PANEL 	1
⑨	SIDE PANEL 	2
⑩	SUPPORT BAR FOR DESKTOP 	1

⑪	REAR PANEL		1
⑫	HEADSET HOLDER		2
⑬	KEYBOARD SLIDERS		1
⑭	BRACKET		2

HARDWARE REQUIRED

(A)		ALLEN BOLT	M6X50MM	6	PCS
(B)		ALLEN BOLT	M6X32MM	8	PCS
(C)		ALLEN BOLT	M6X12MM	8	PCS
(D)		ALLEN SCREW	M6X50MM	6	PCS
(E)		PHILLIPS SCREW	M4X12MM	16	PCS
(F)		PHILLIPS BOLT&WASHER	M5X19MM	36	PCS
(G)		CAM BOLT		6	PCS
(H)		CAM LOCK		6	PCS
(I)		STUD		4	PCS
(J)		GROMMET		2	PCS
(K)		ALLEN WRENCH		1	PCS

Attention

***Some number parts listed on the instruction sheet may not be in parts bag as they may already be assembled.
Carefully check parts and packing materials prior to ordering replacements.

Step1

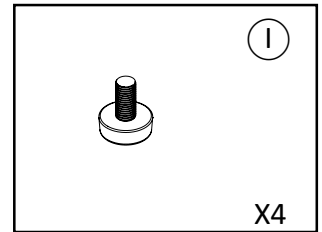
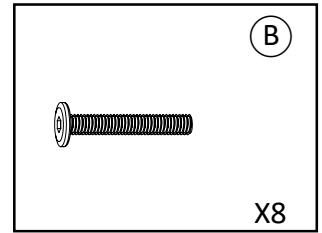
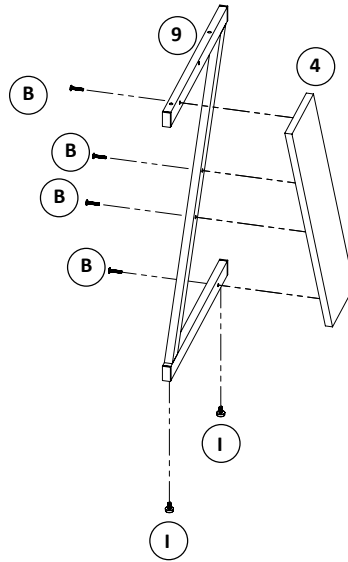
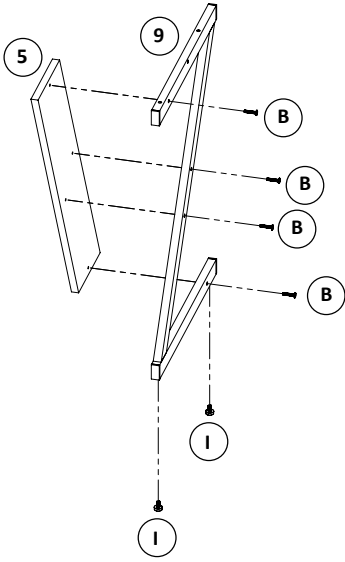

Step2

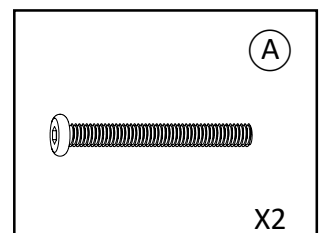
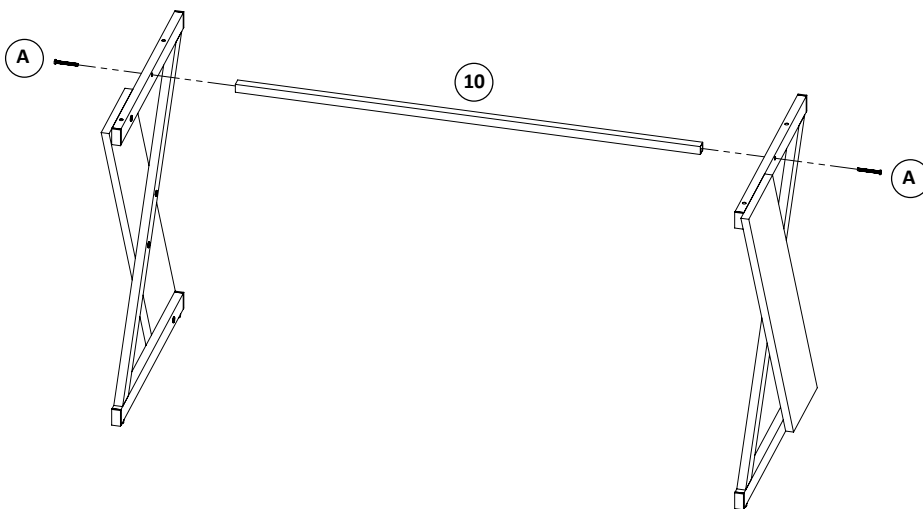

Step3

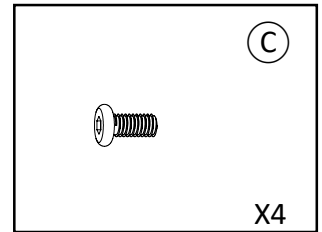
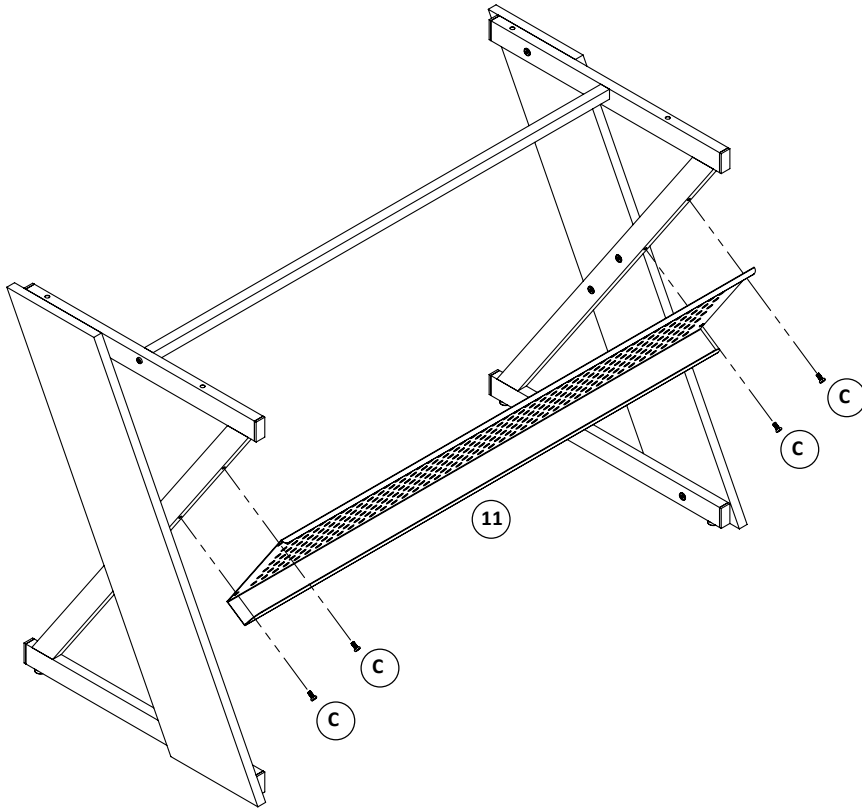

Step4

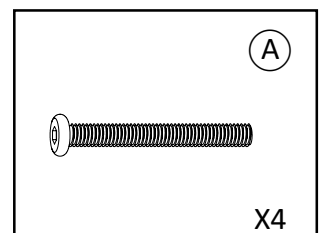
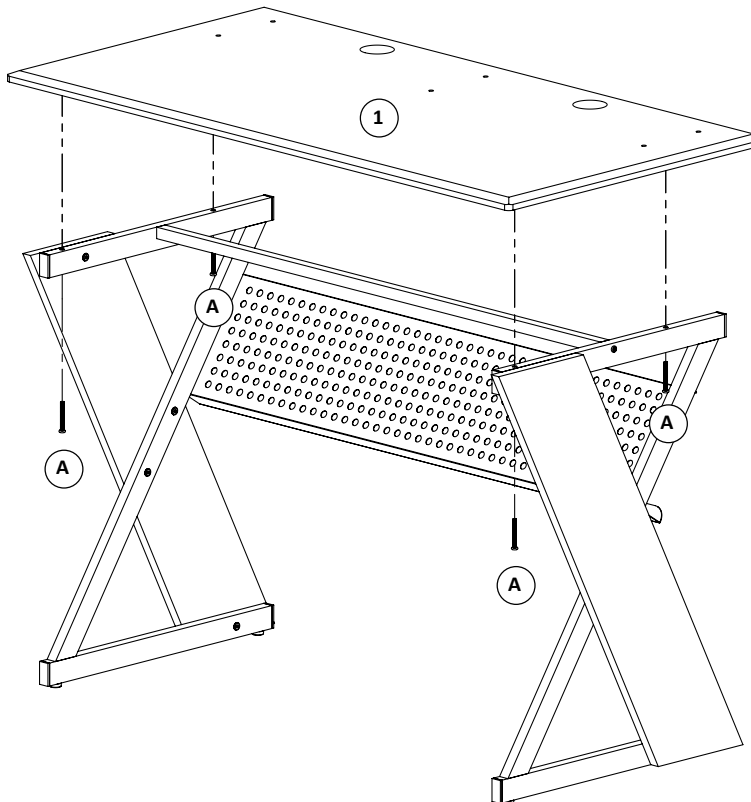

Step 5

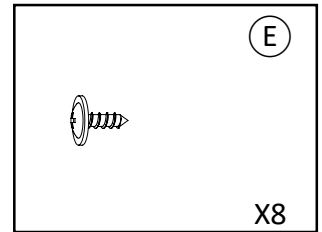
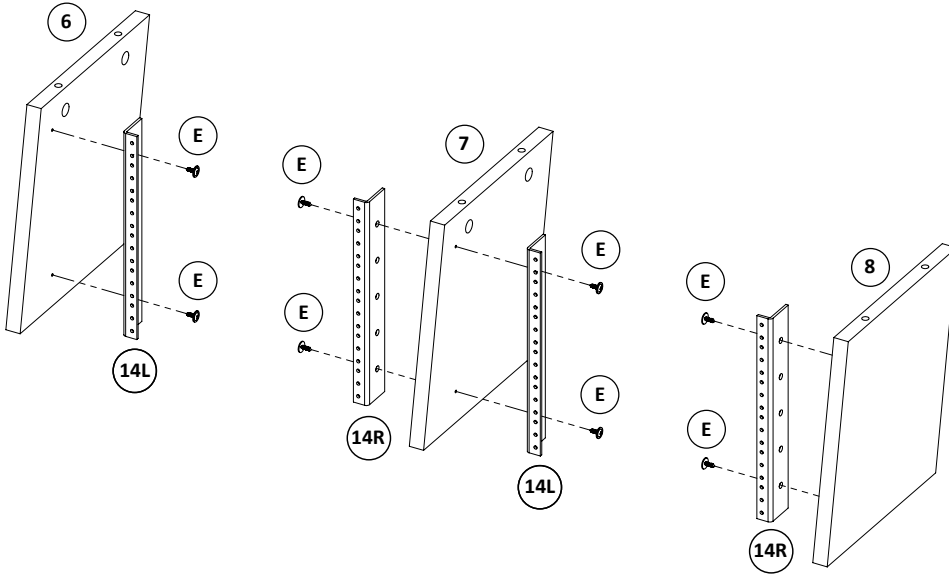

Step 6

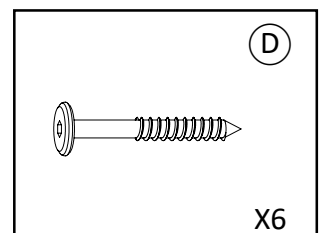
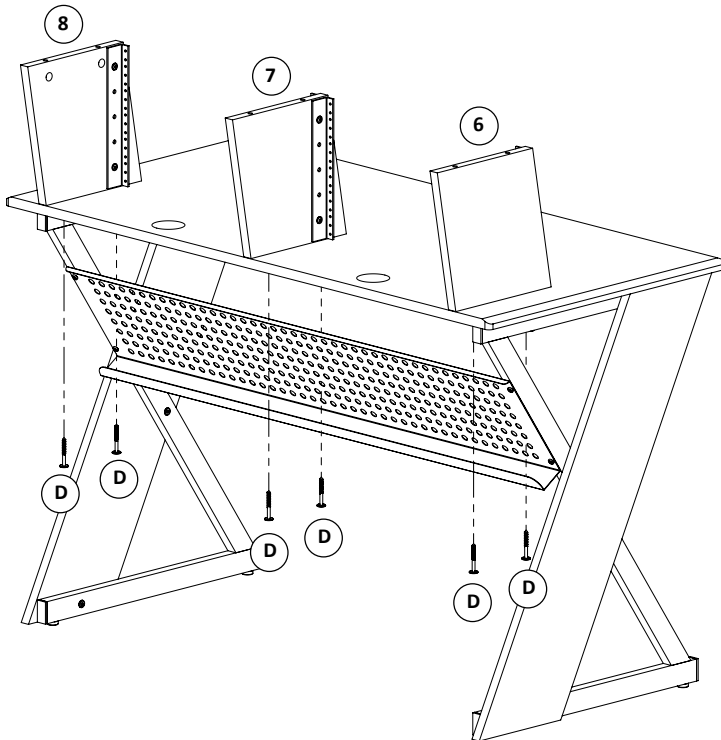

Step 7

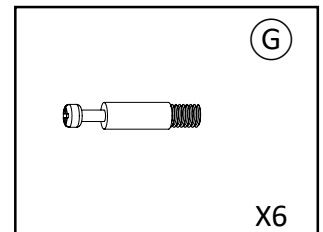
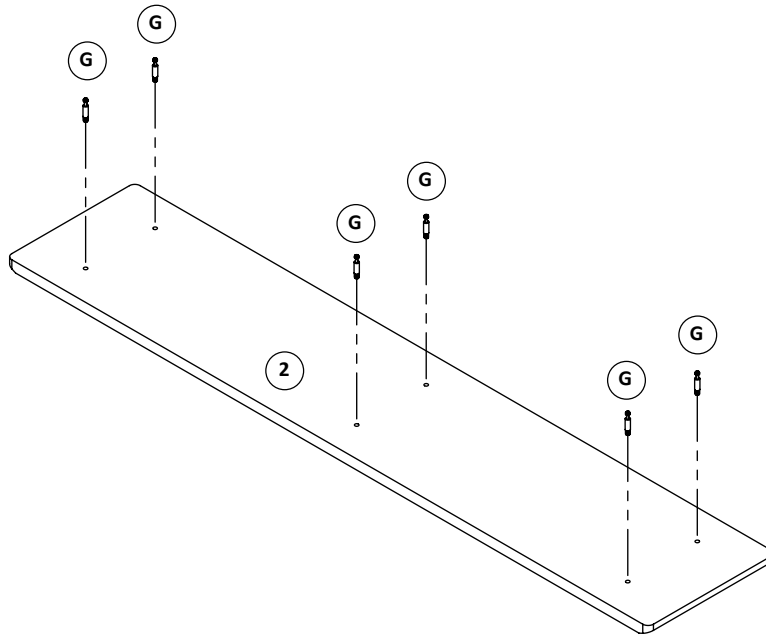

Step 8

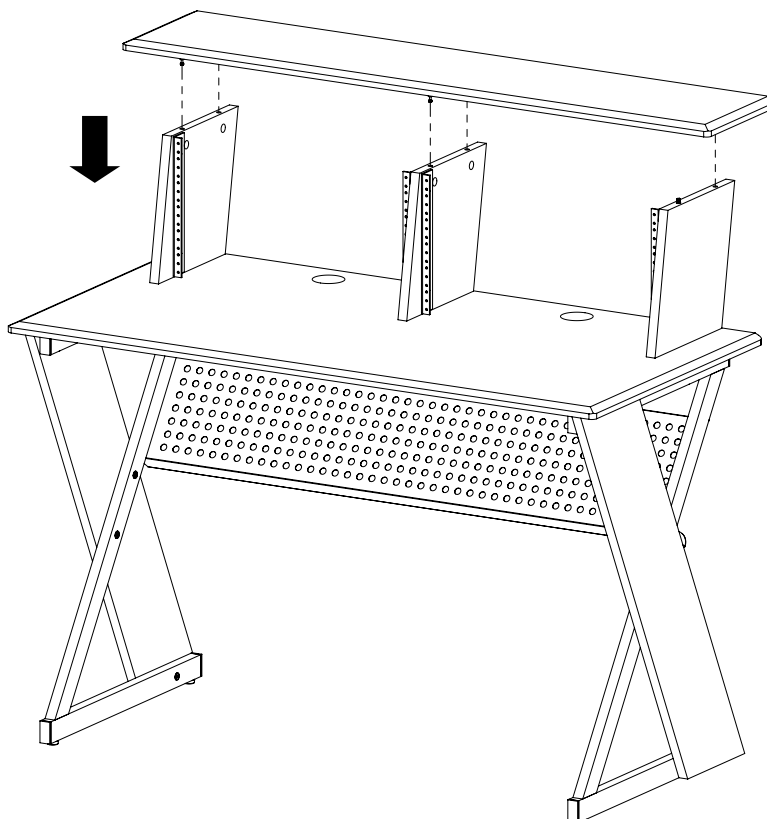

Step9

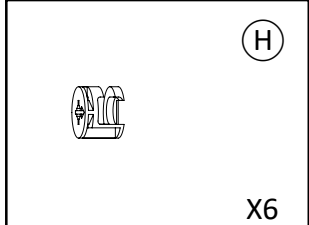
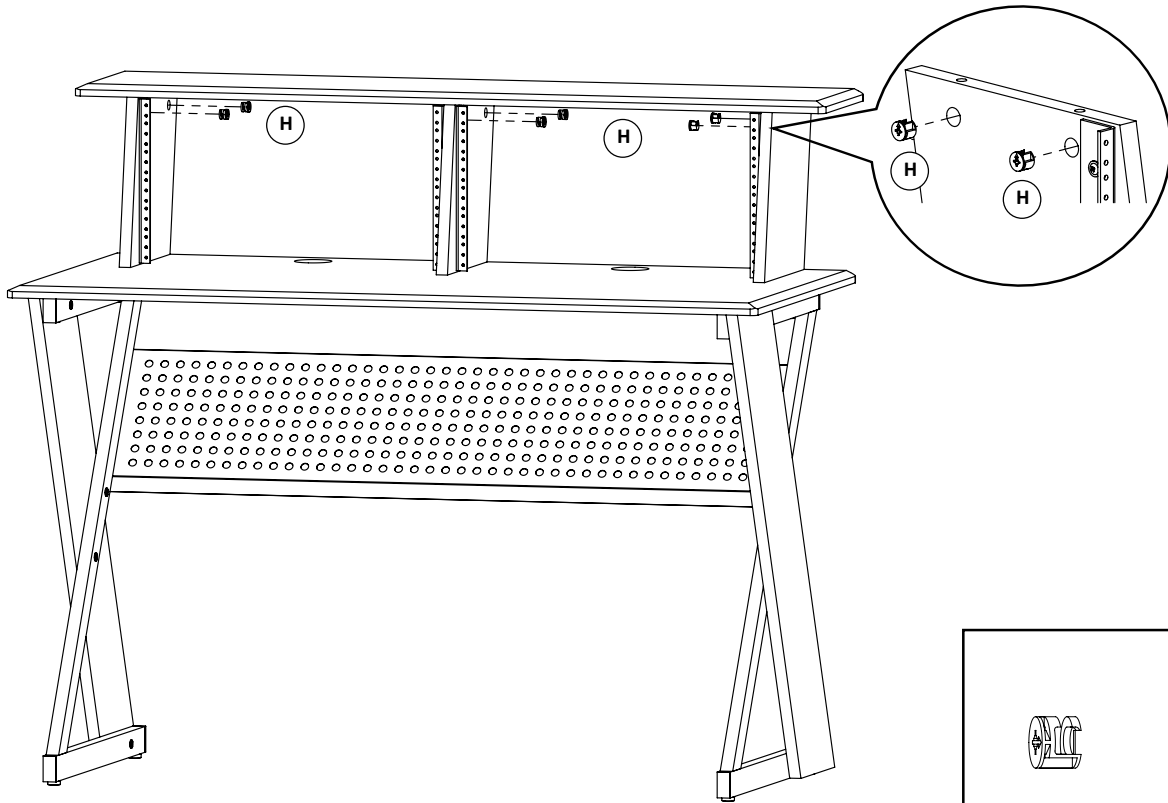

Step10

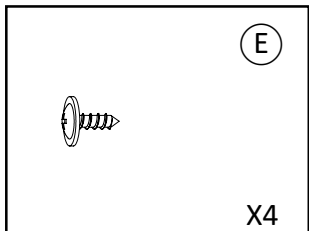
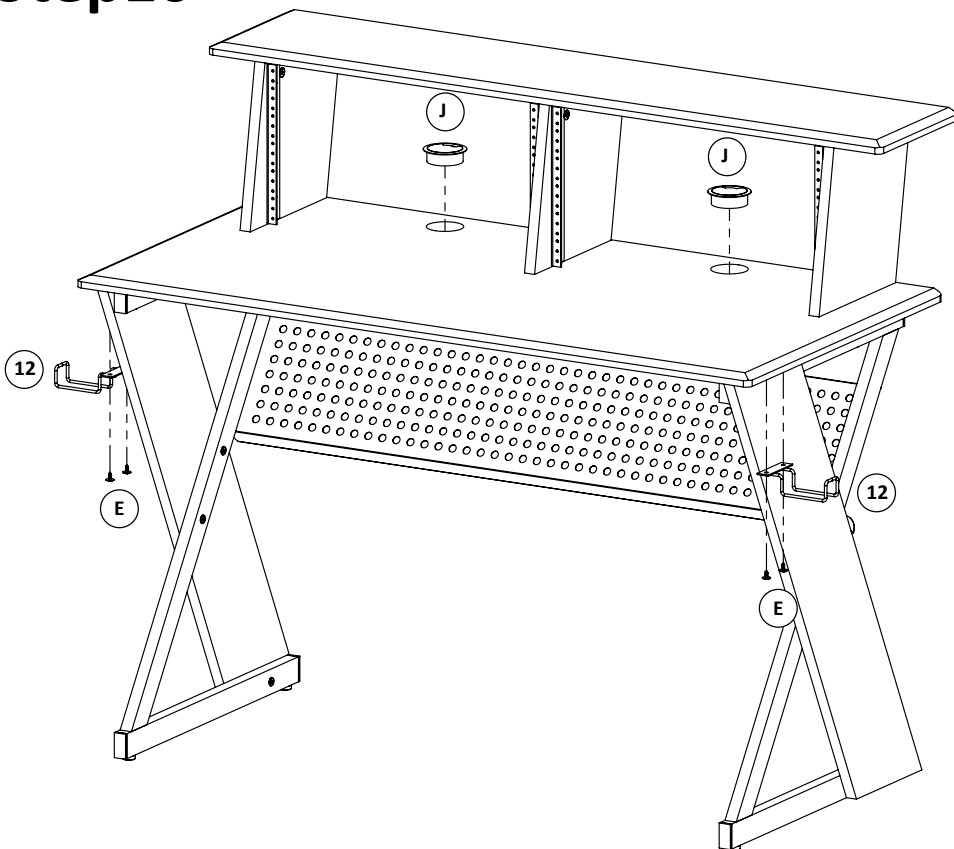

Step11

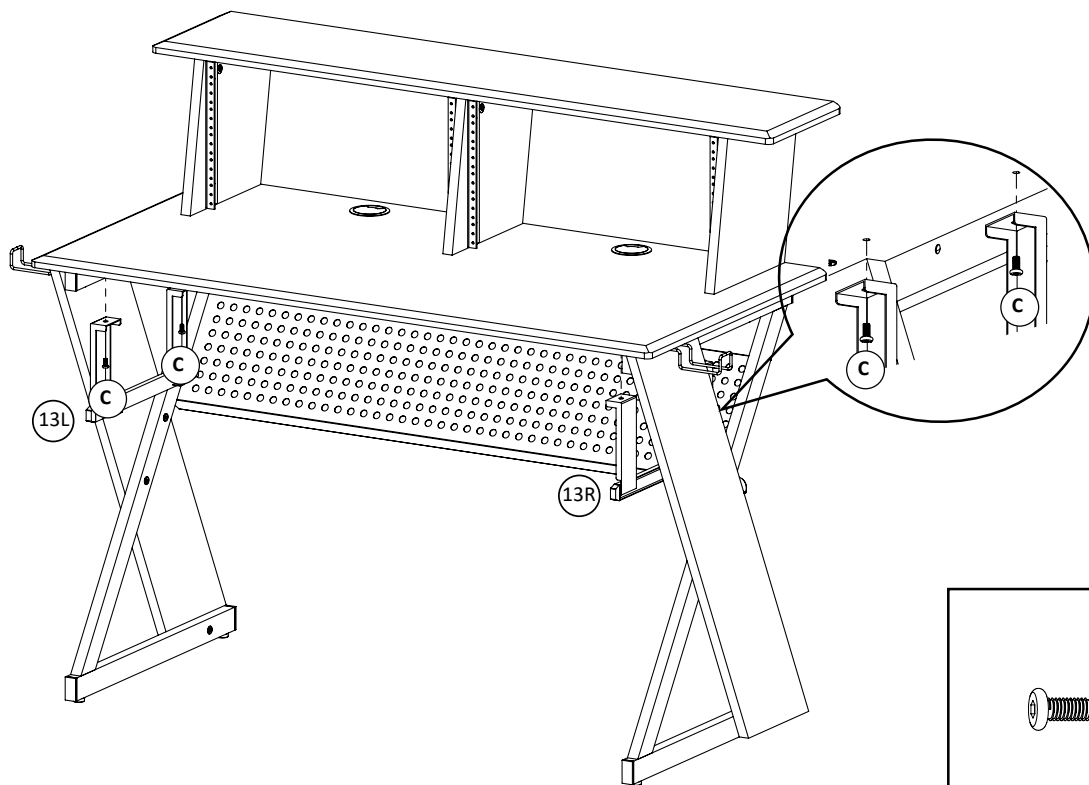

Step12

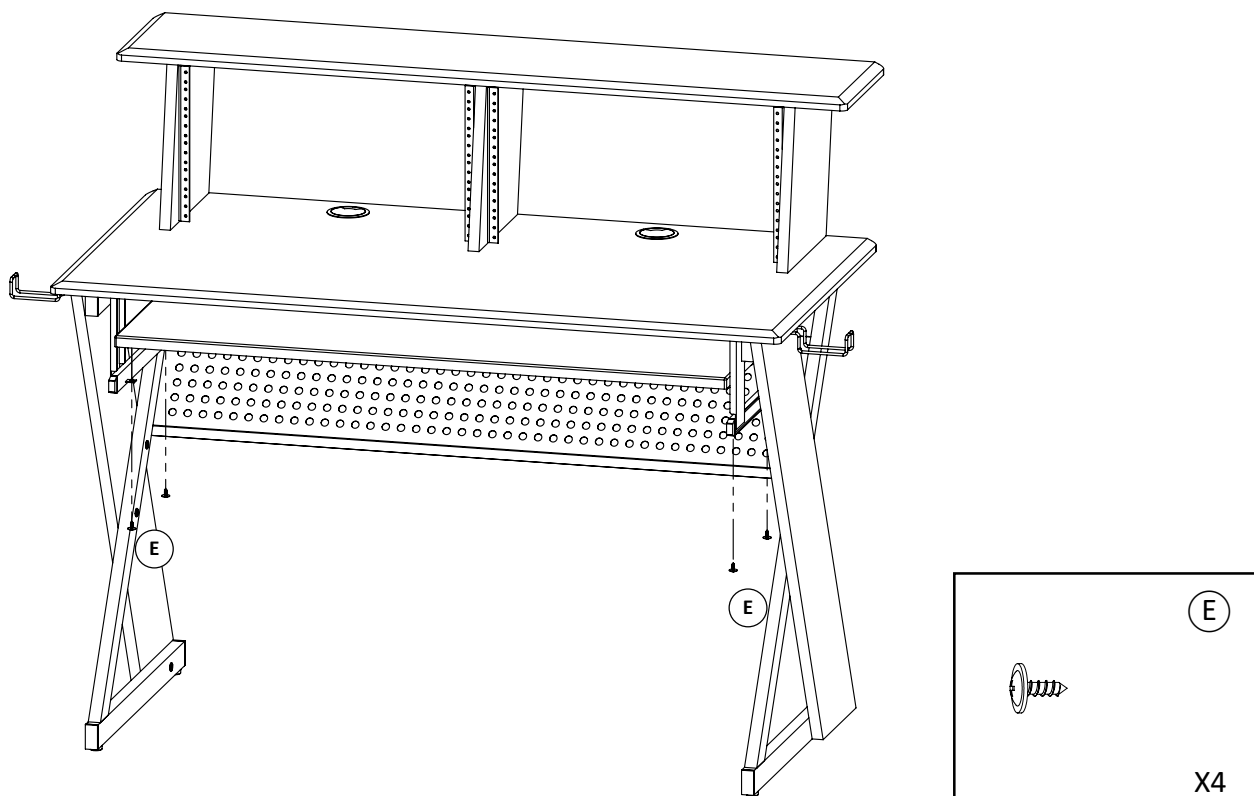

Step13

