

About the Wood and Finish

This product has been carefully crafted of: MDF, solid pine wood and/or pine veneers. These materials derive from plantations, a renewable and well managed forest, therefore, not endangering the environment. The highest quality standards have been implemented to assure a sturdy and reliable product. Due to the natural variances in the

graining of wood, you may notice subtle differences in the shading and tone of the color stain, warp, holes, wood knots and also small cracks. This is not a defect.

But rather a result of the natural beauty of the wood itself.

AONNE
FURNITURE

Care and maintenance:

Dust when needed using a smooth, dry cloth. Household furniture polish can be used occasionally to restore luster.

#39235

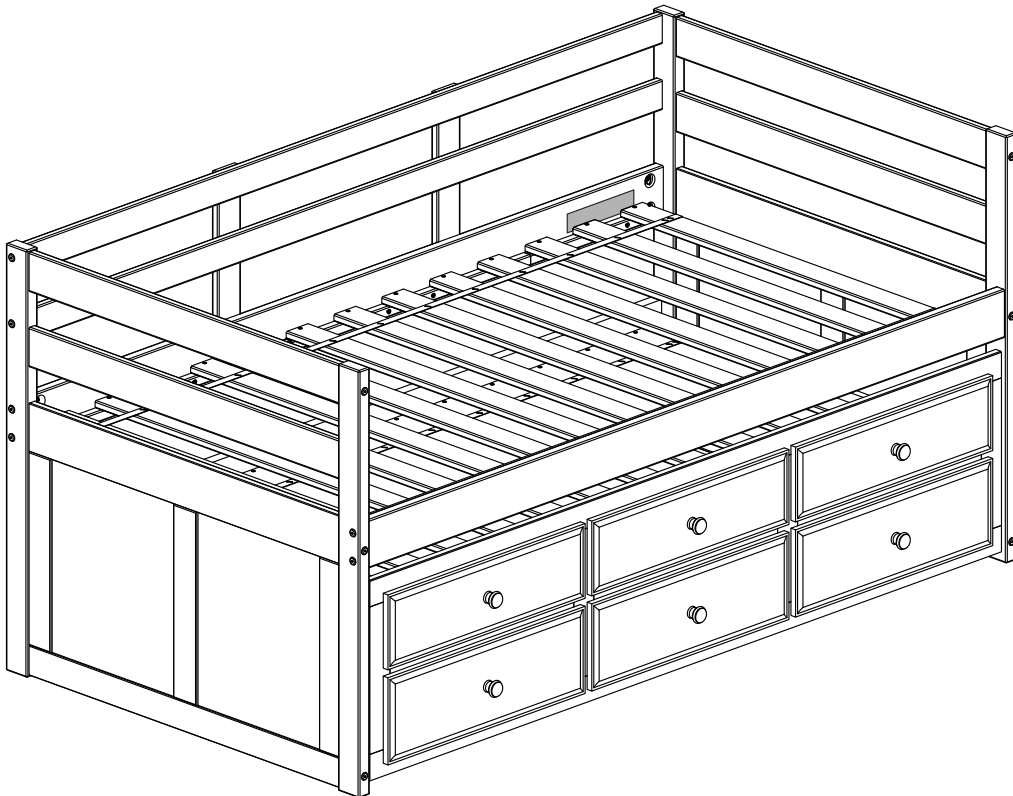

Thank you for purchasing this quality product. Be sure to check all packing material carefully for small parts which may have come loose inside the carton during shipment. Separate, identify and count all parts and hardware. Compare with the parts list to be sure that all parts are included.

”DO NOT TIGHTEN SCREWS UNTIL COMPLETELY ASSEMBLED”

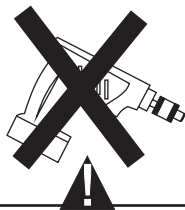

*Use of power tool to assemble this product will invalidate any claim and damage this product making unsafe !
*Please assemble on a clean soft surface to avoid damage.

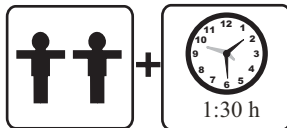

Tools Required

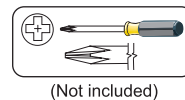

(Not included)

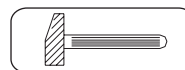

(Not included)

IMPORTANT:

PLEASE READ INSTRUCTION BEFORE STARTING THE ASSEMBLY

Part List: 39235 - Twin Captains Bed

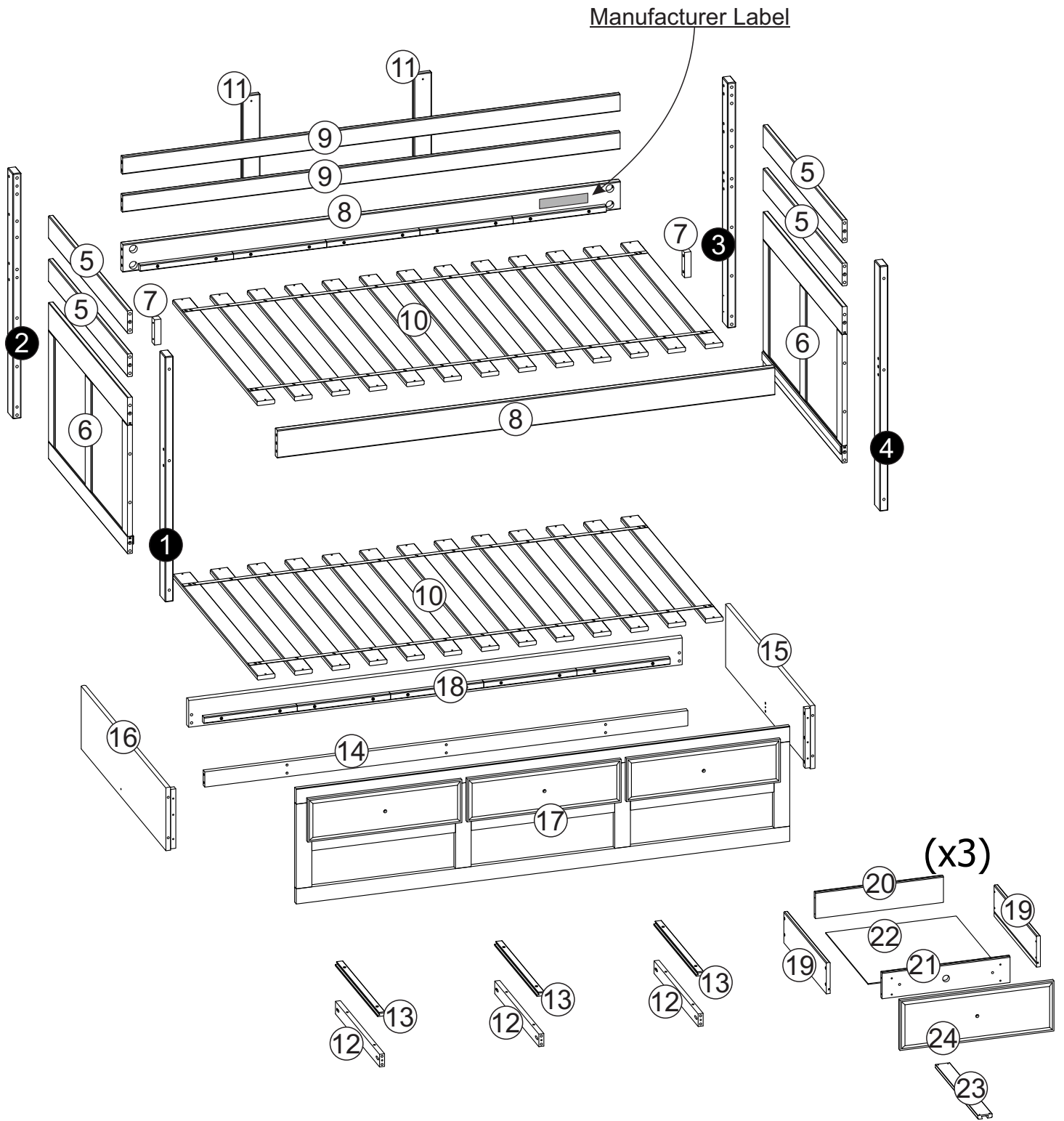

Identifying the Hardware/part list - Identify the hardware using the illustrations below.

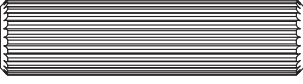
A  Qty **40**
1 9/16" Wooden Dowel (10 x 40mm)

B  Qty **32**
1" Wooden Dowel (8 x 25mm)

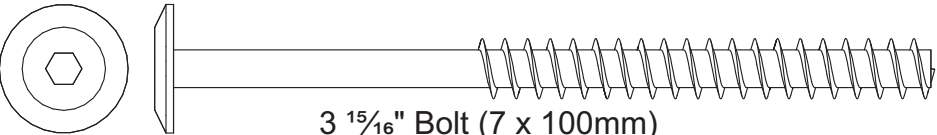
C  Qty **12**
3 15/16" Bolt (7 x 100mm)

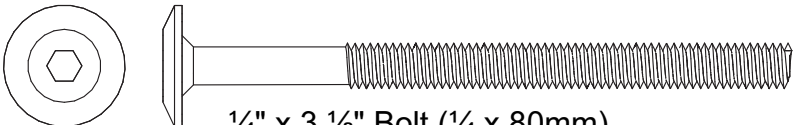
D  Qty **08**
1/4" x 3 1/8" Bolt (1/4 x 80mm)

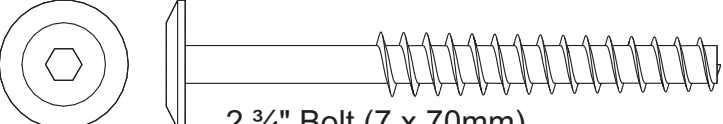
E  Qty **04**
2 3/4" Bolt (7 x 70mm)

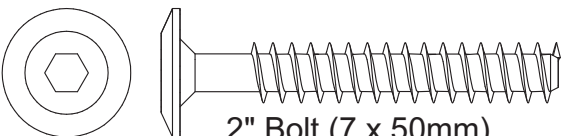
F  Qty **04**
2" Bolt (7 x 50mm)

G  1/4" Elliptical Nut Qty **08**

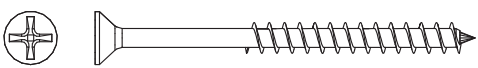
H  Qty **02**
2" Screw (4 x 50mm)

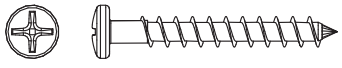
I  Qty **122**
1 3/16" Screw (4 x 30mm)

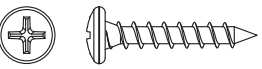
J  Qty **12**
3/4" Screw (3.5 x 20mm)

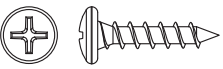
K  Qty **22**
5/8" Screw (3.5 x 16mm)

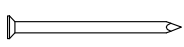
L  Qty **12**
Nail 10x10

M  Caster Qty **04**

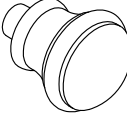
N  Knob Qty **06**

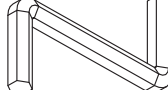
O  Allen wrench Qty **01**

P  Stopper Qty **06**

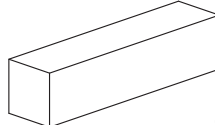
Q  Wooden spacer Qty **02**
8 9/16" (217mm)

*Actual size of screws and bolts, for measurements checking.

01

HEADBOARD / FOOTBOARD

Insert wooden dowels (A) into the holes, as shown in the diagram.

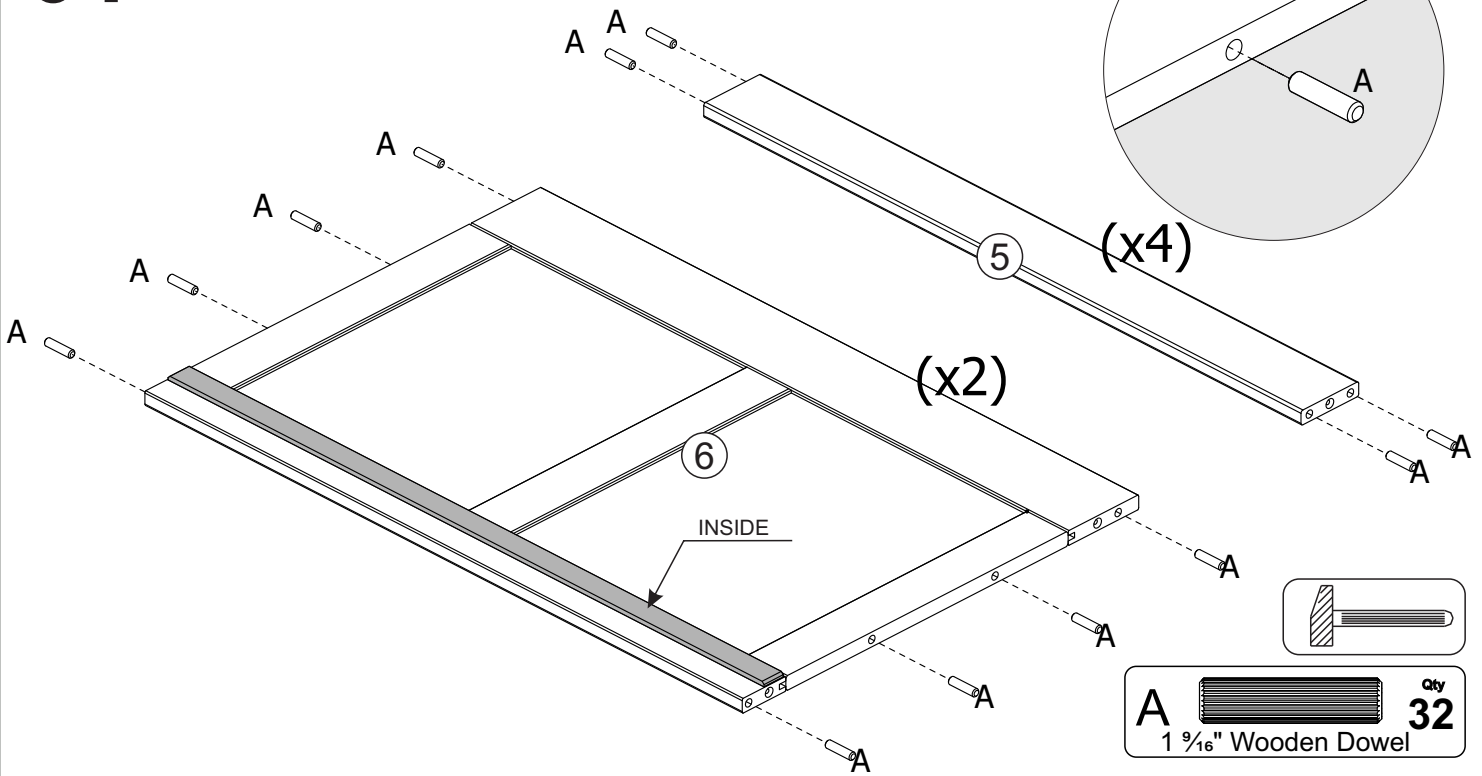

02

Attach crossbars 5 and bottom panel 6 at the legs 1, 2, 3 and 4 with bolts (C) using the allen wrench (O), as shown in the diagram.

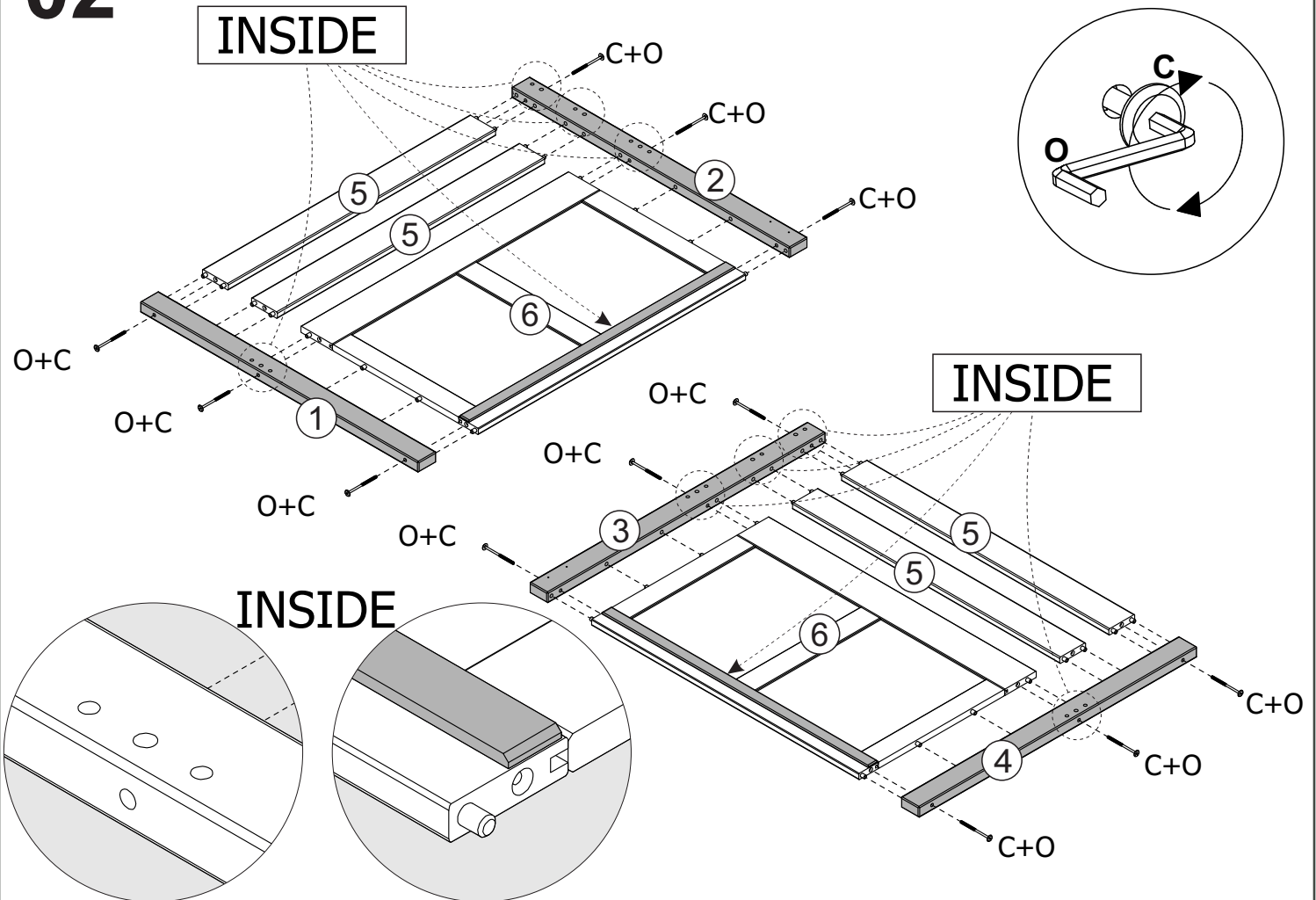

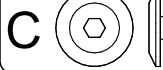

C  $3 \frac{15}{16}$ " Bolt Qty **12**

O  Allen wrench Qty **01**

03

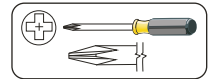
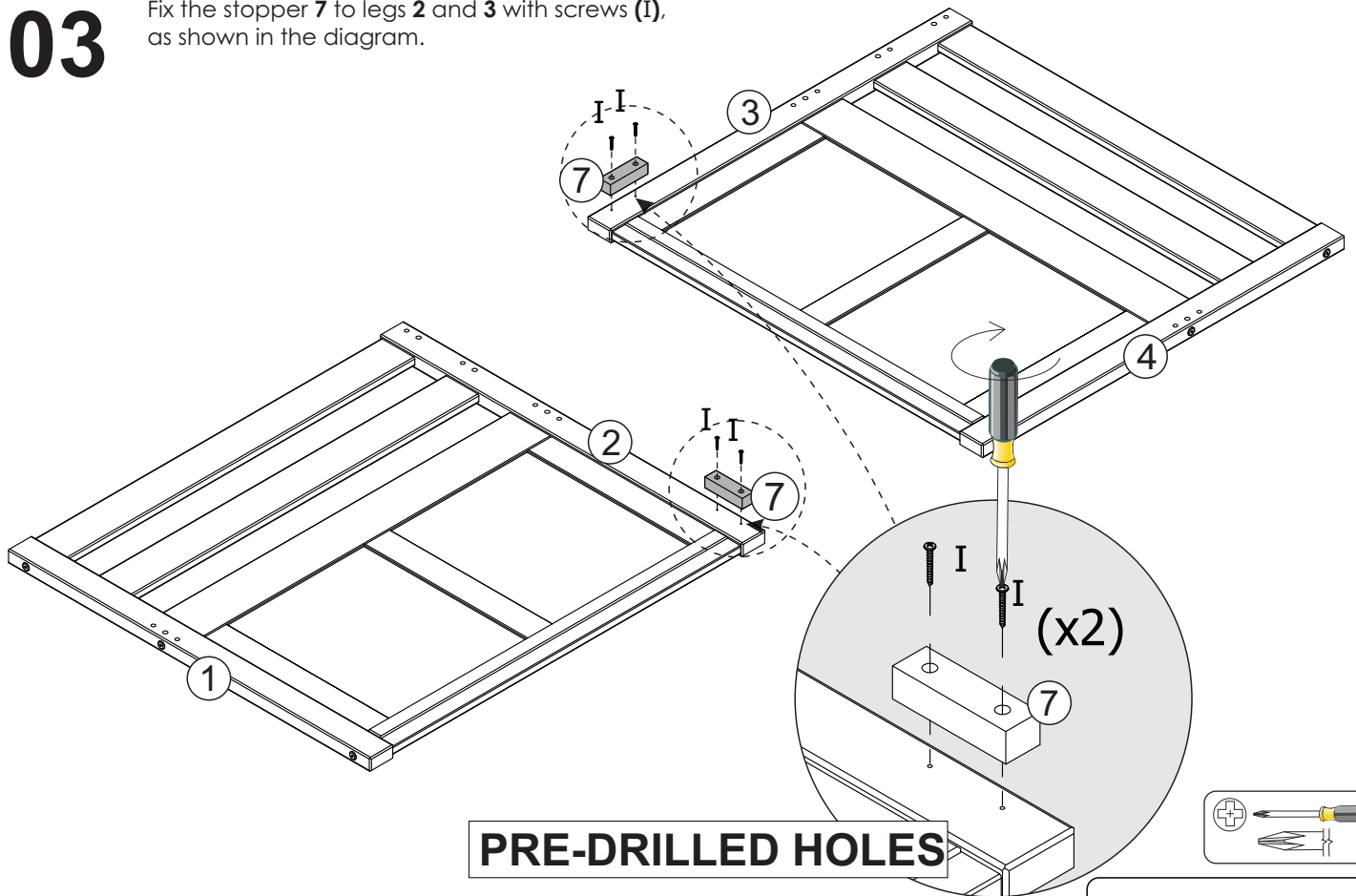
Fix the stopper 7 to legs 2 and 3 with screws (I), as shown in the diagram.





I  Qty **04**
1 3/16" Screw

04

BED RAILS / GUARDRAILS

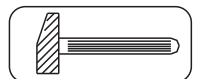
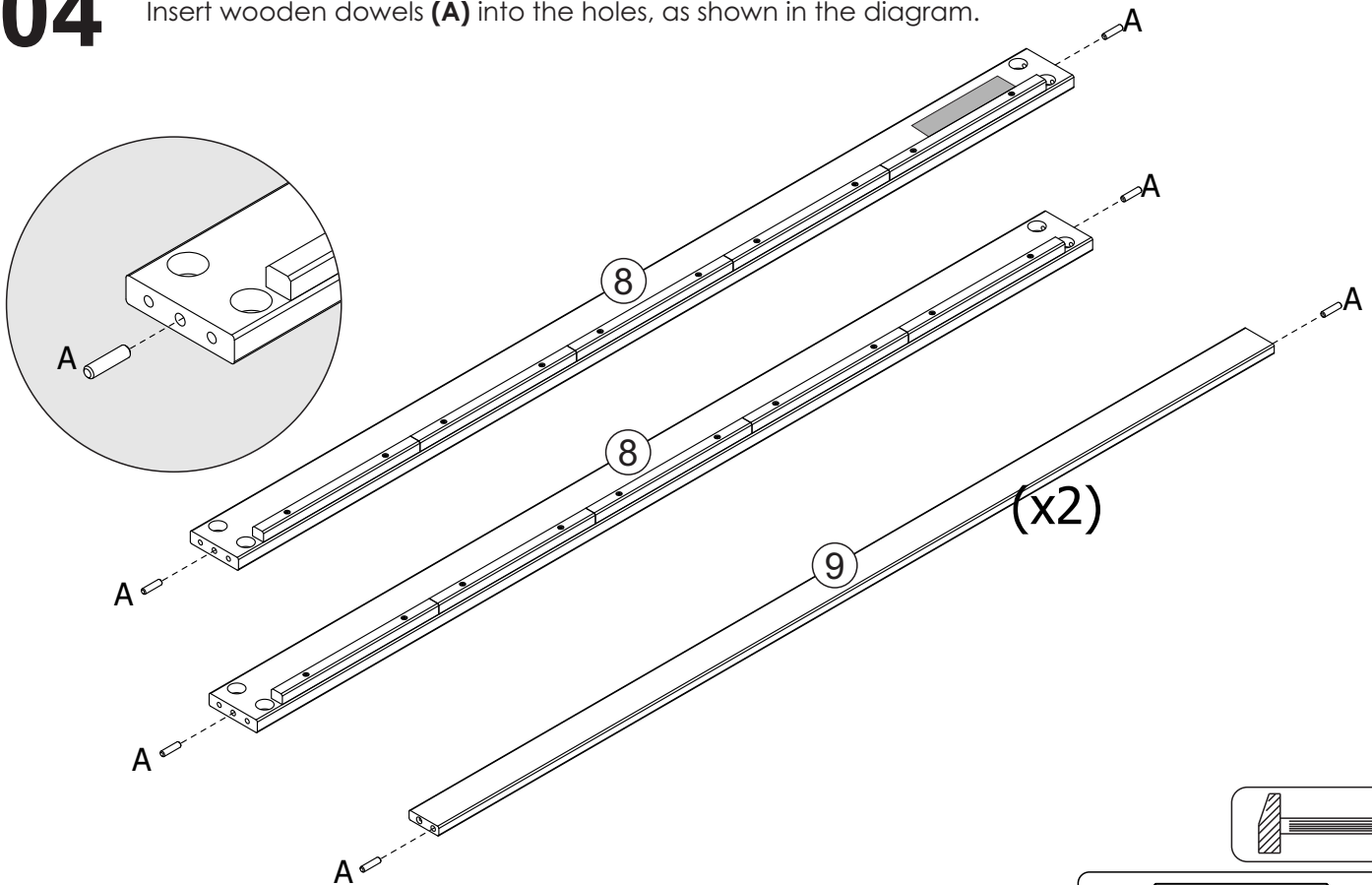
Insert wooden dowels (A) into the holes, as shown in the diagram.



A  Qty **08**
1 9/16" Wooden Dowel

05

First, fix one of the headboard/footboard to the rail **8** and then the other headboard, with bolts (**D**) and elliptical nuts (**G**), using the allen wrench (**O**). Do not tighten the bolts until **step # 07**, in order to attach the other rail and guardrails.



INSERT AND ATTACH BOLTS AND NUTS (D&G), BUT DO NOT TIGHTEN UNTIL STEP #07

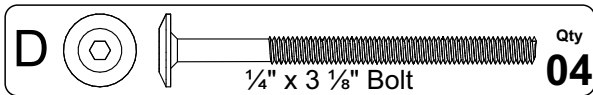
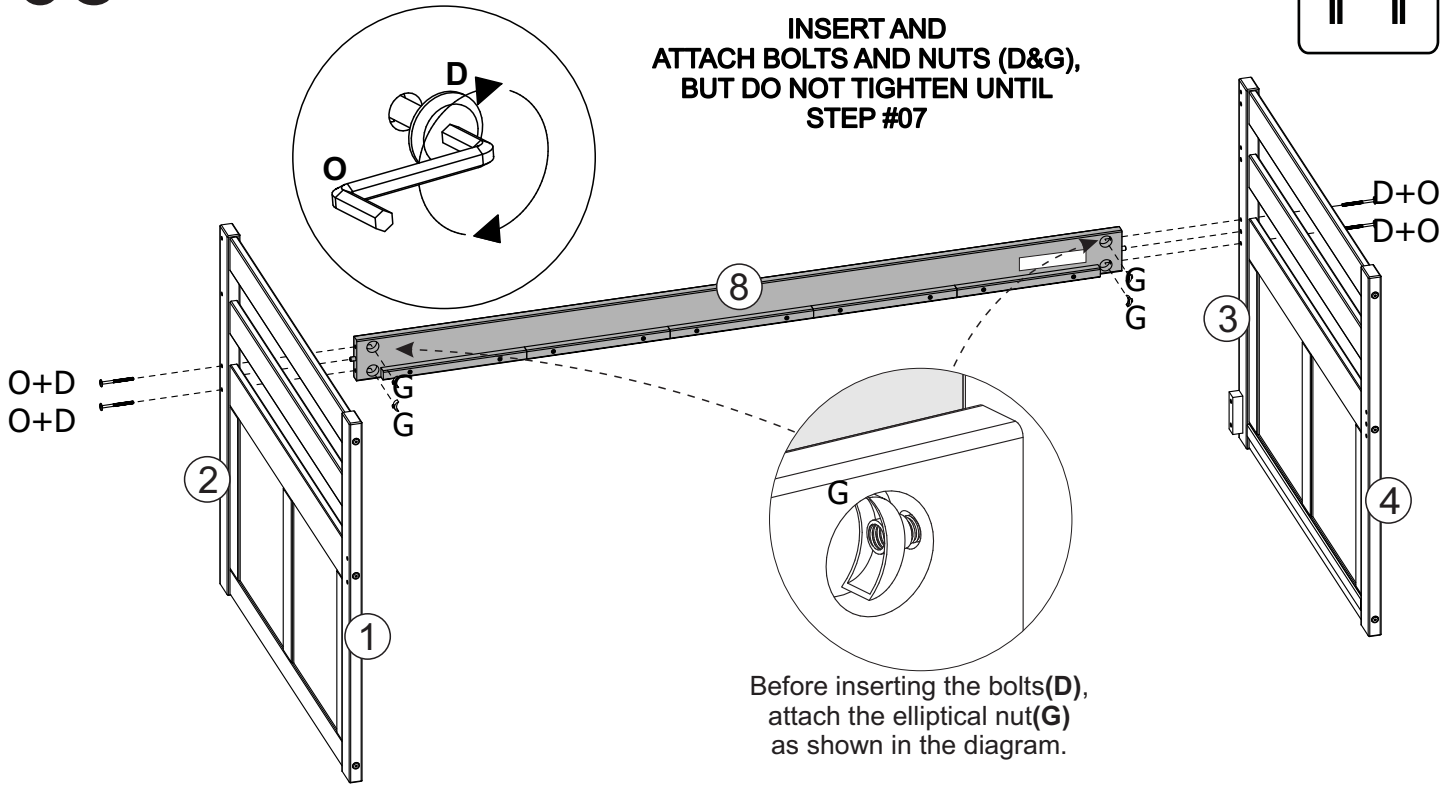

06

Attach the other rail with bolts (**D**) and elliptical nuts (**G**), using the Allen wrench (**O**). Do not tighten the bolts in order to attach the guardrails in **step # 7**.



INSERT AND ATTACH BOLTS AND NUTS (D&G), BUT DO NOT TIGHTEN UNTIL STEP #07

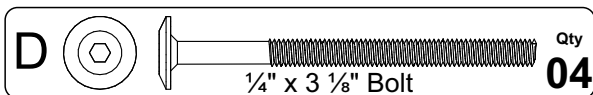
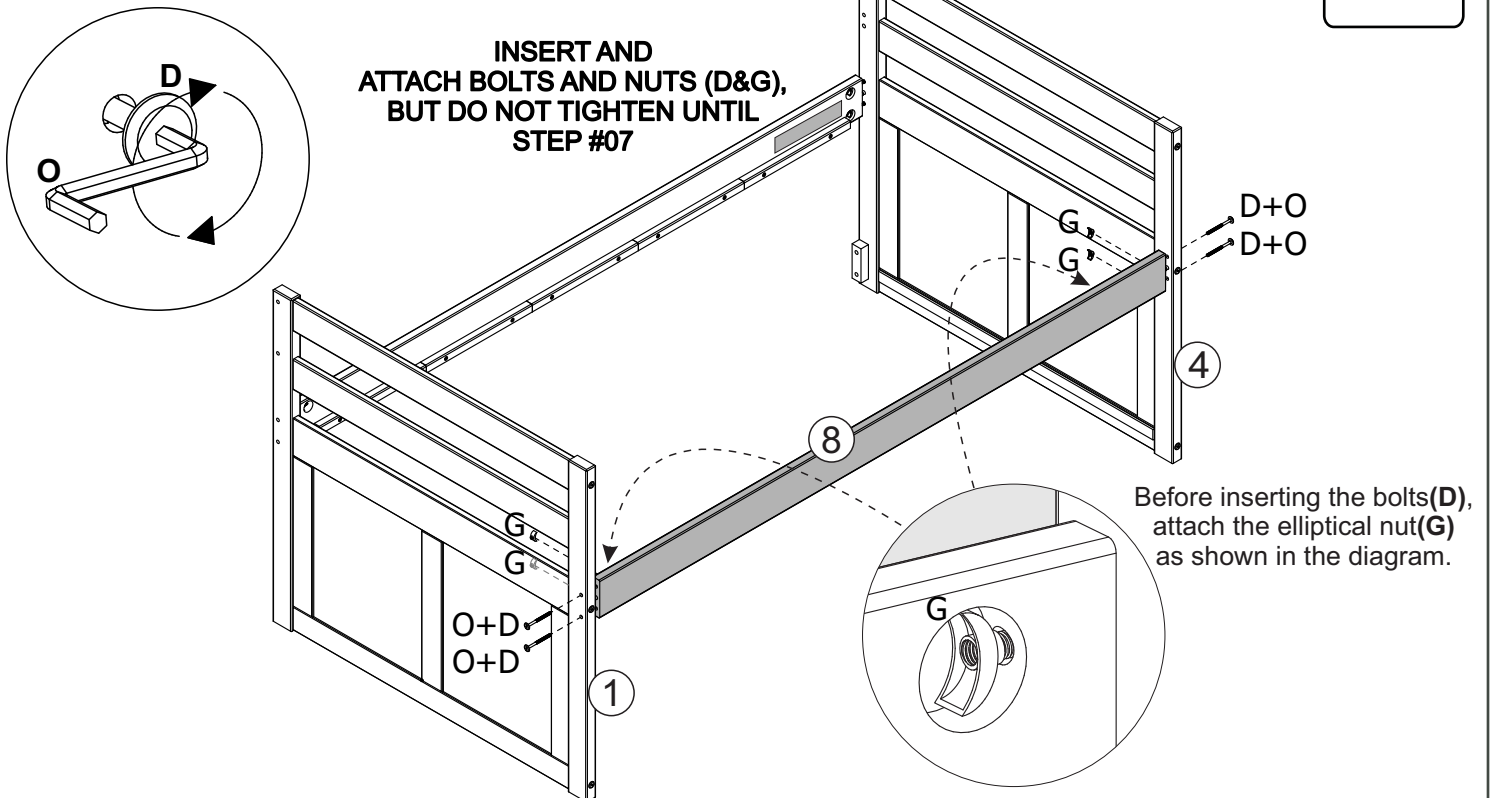

07

Attach guardrails **9** to the headboard/footboard with bolts **(E)** using the allen wrench **(O)**, as shown in the diagram.
At this time, tighten all bolts.

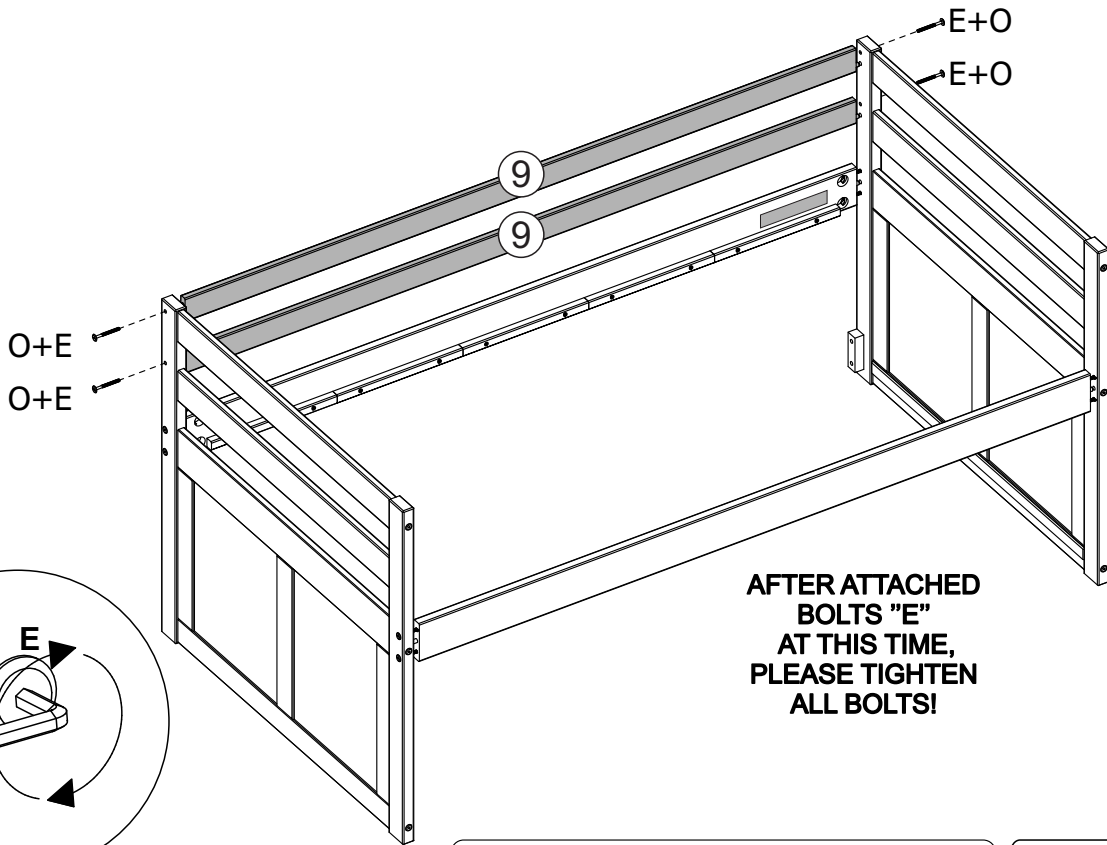
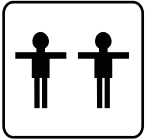

AFTER ATTACHED BOLTS "E" AT THIS TIME, PLEASE TIGHTEN ALL BOLTS!

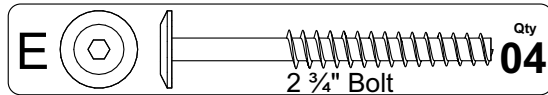

08

SLATS

Attach the first slat aligned with the rail support with the screws **(I)**.
Stretch the set and secure all slats.

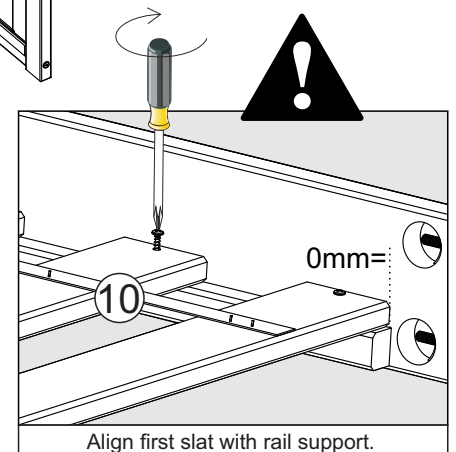
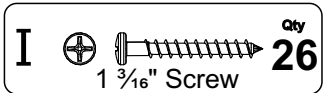
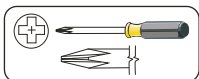
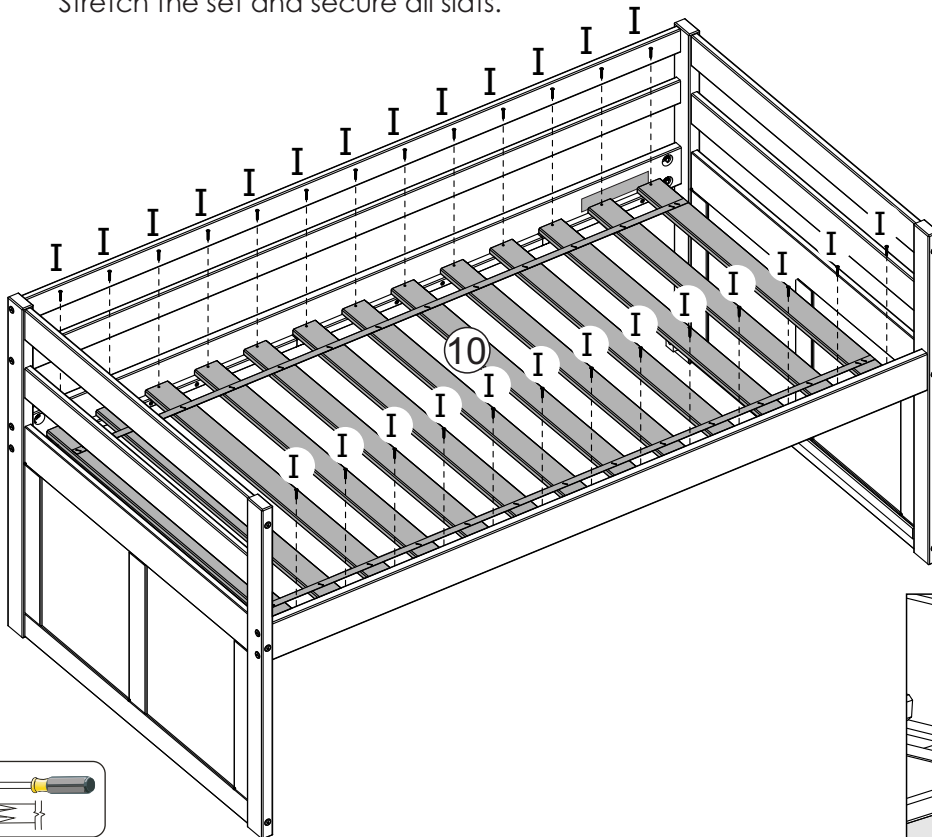

09

Attach the supports **11** to the guardrails **9** using the screws **(I)**.

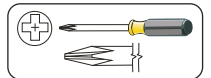
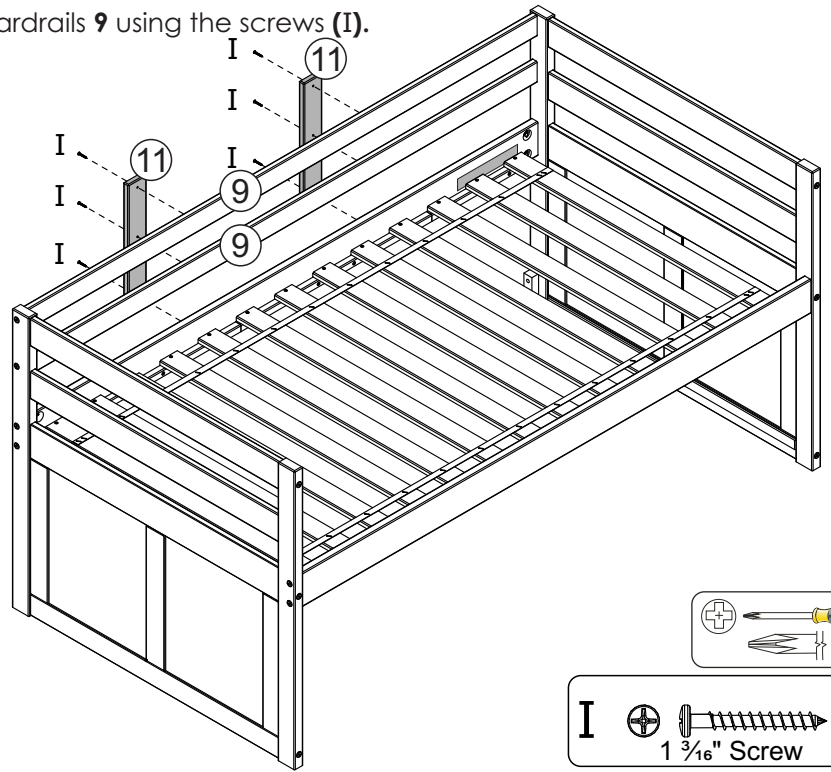
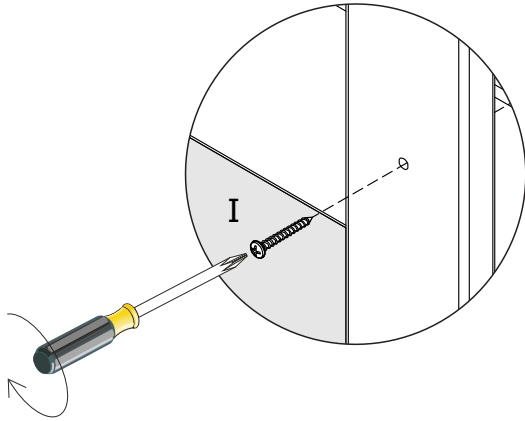

I  **1 3/16" Screw** Qty **06**

10

TRUNDLE COMPONENTS

Insert wooden dowels **(B)** into the holes, as shown in the diagram. **SPECIAL ATTENTION AFTER THIS STEP** because it has back and front sides. Please check the measurements between the holes to identify front and back sides.

(x3)

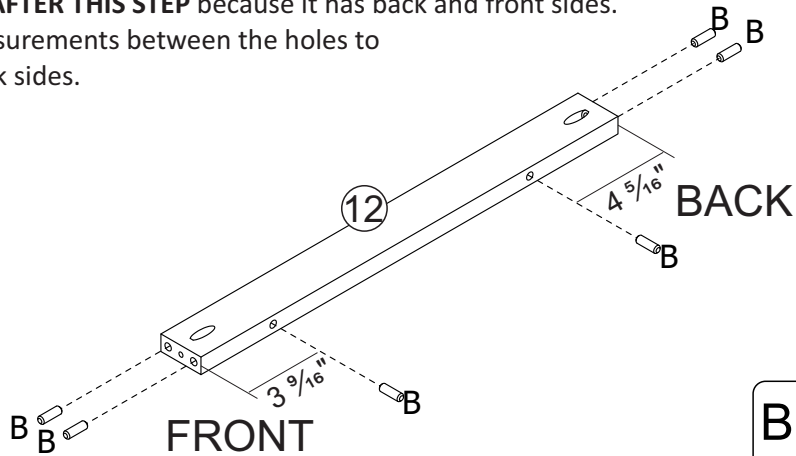
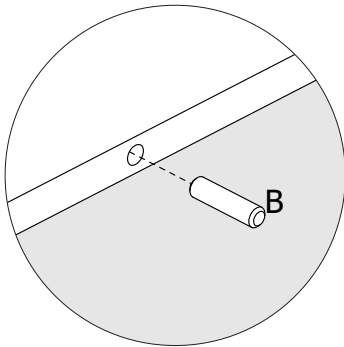

B  Qty **18**
1" Wooden Dowel

11

Attach part **13** on support **12** with screws **(I)**, aligning the beveled edge forward. In support **12** the front side is the shortest measure up to the wooden dowel.

(x3)

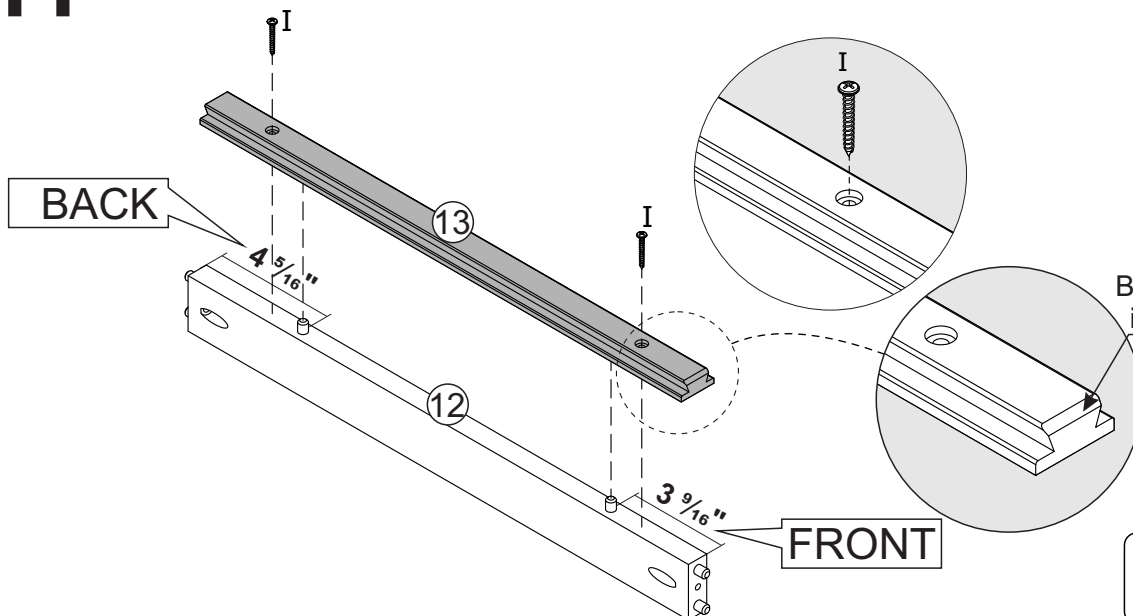

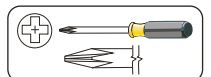

Attention
Beveled edge
is front side



I  **1 3/16" Screw** Qty **06**

12

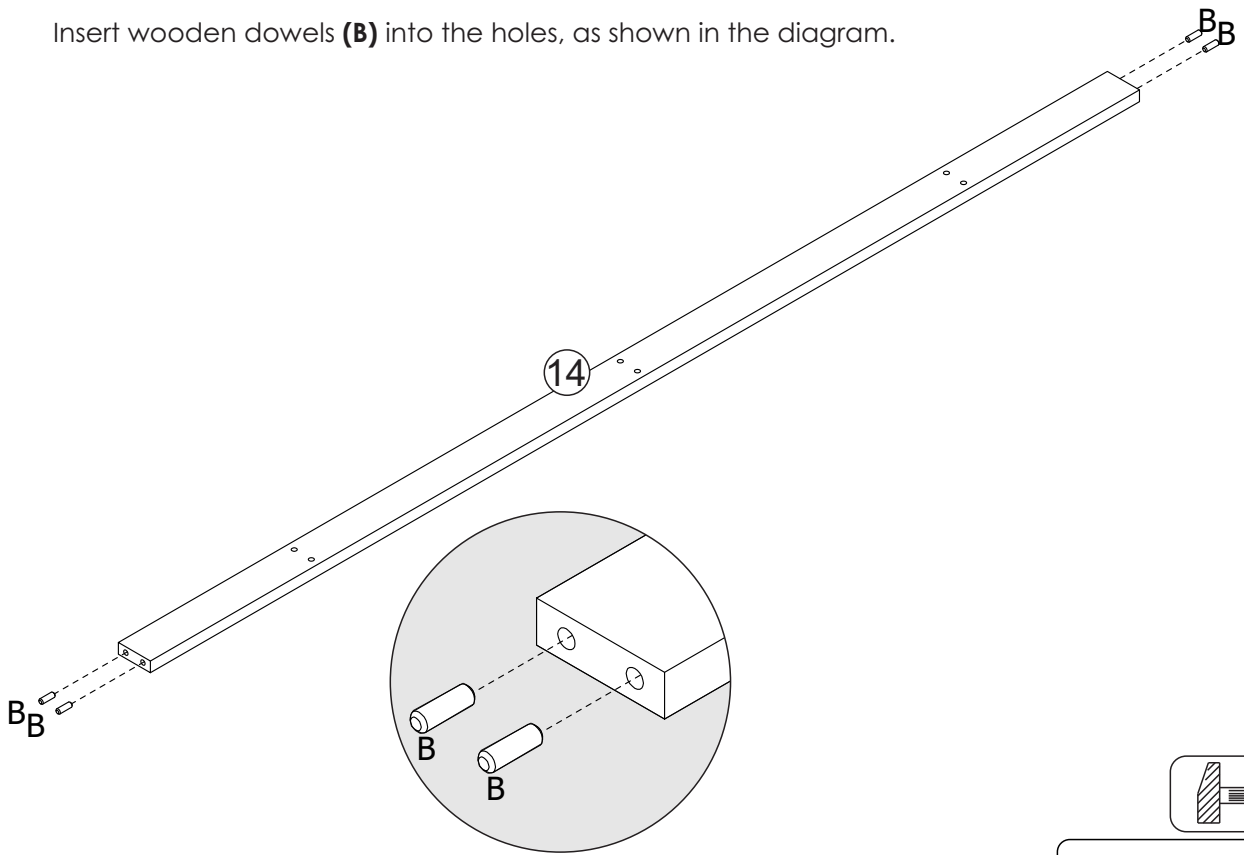
Insert wooden dowels (B) into the holes, as shown in the diagram.



B Qty **04**
1" Wooden Dowel

13

Attach support 12 to the part 14 with screws (I), as shown in the diagram.

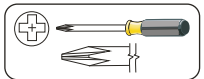
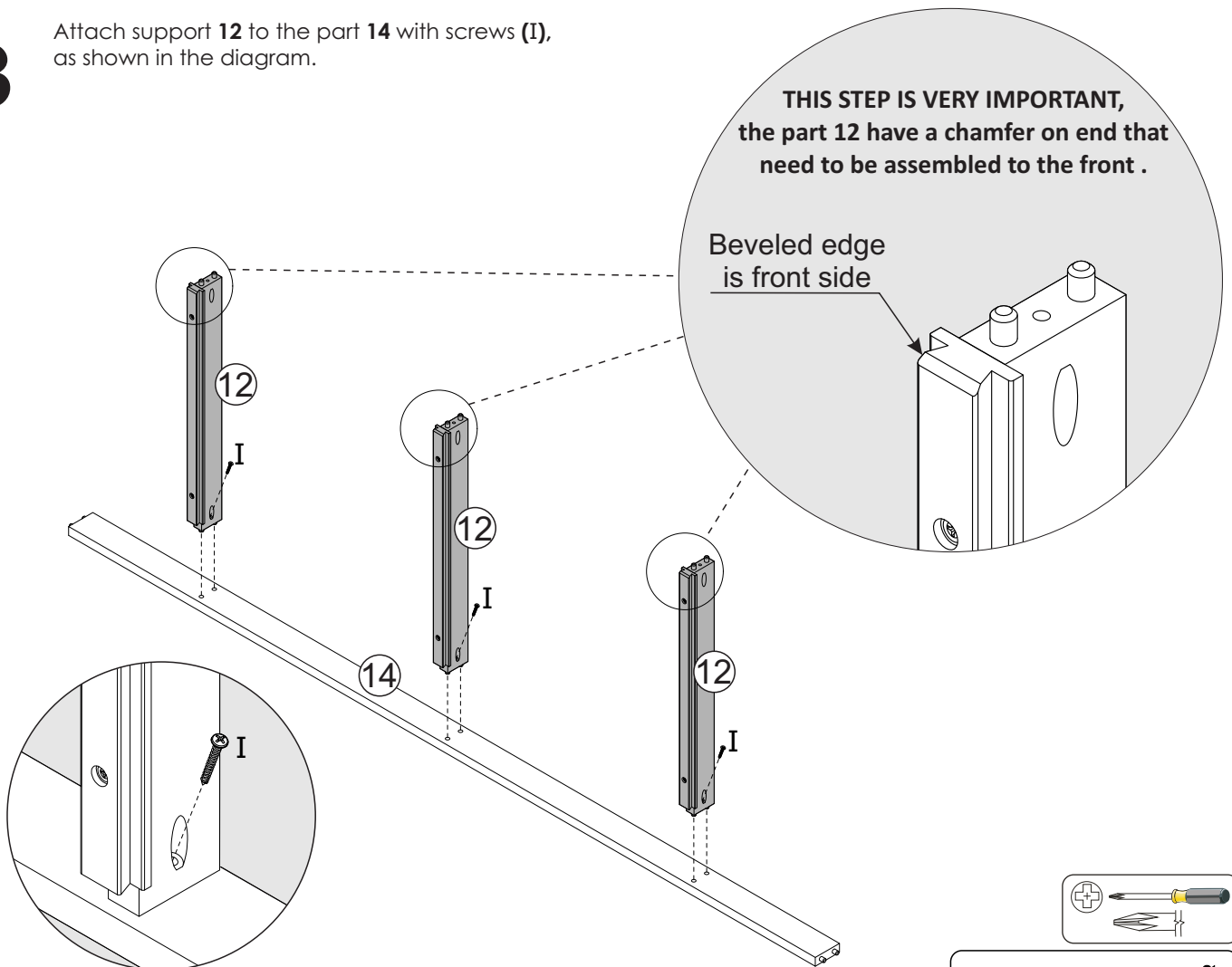

I Qty **03**
1 3/16" Screw

14

Insert wooden dowels (**B**) into the holes.
Attach the casters (**M**), about 2" away from edge,
to the sides **15** and **16** using the screws (**K**),
as shown in the diagram.

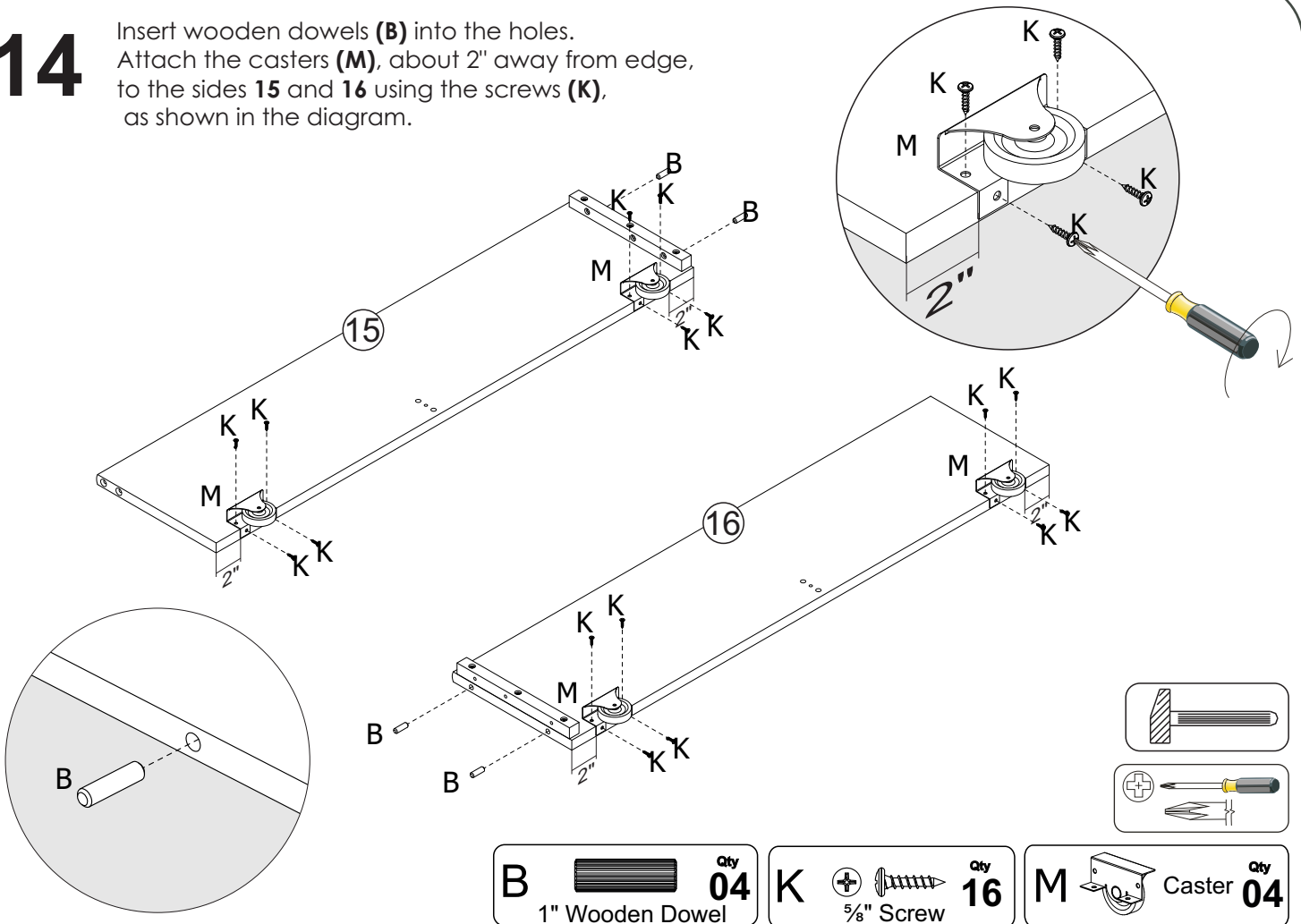

15

Attach the sides **15** and **16** to the part **14** with screws (**H**),
as shown in the diagram.

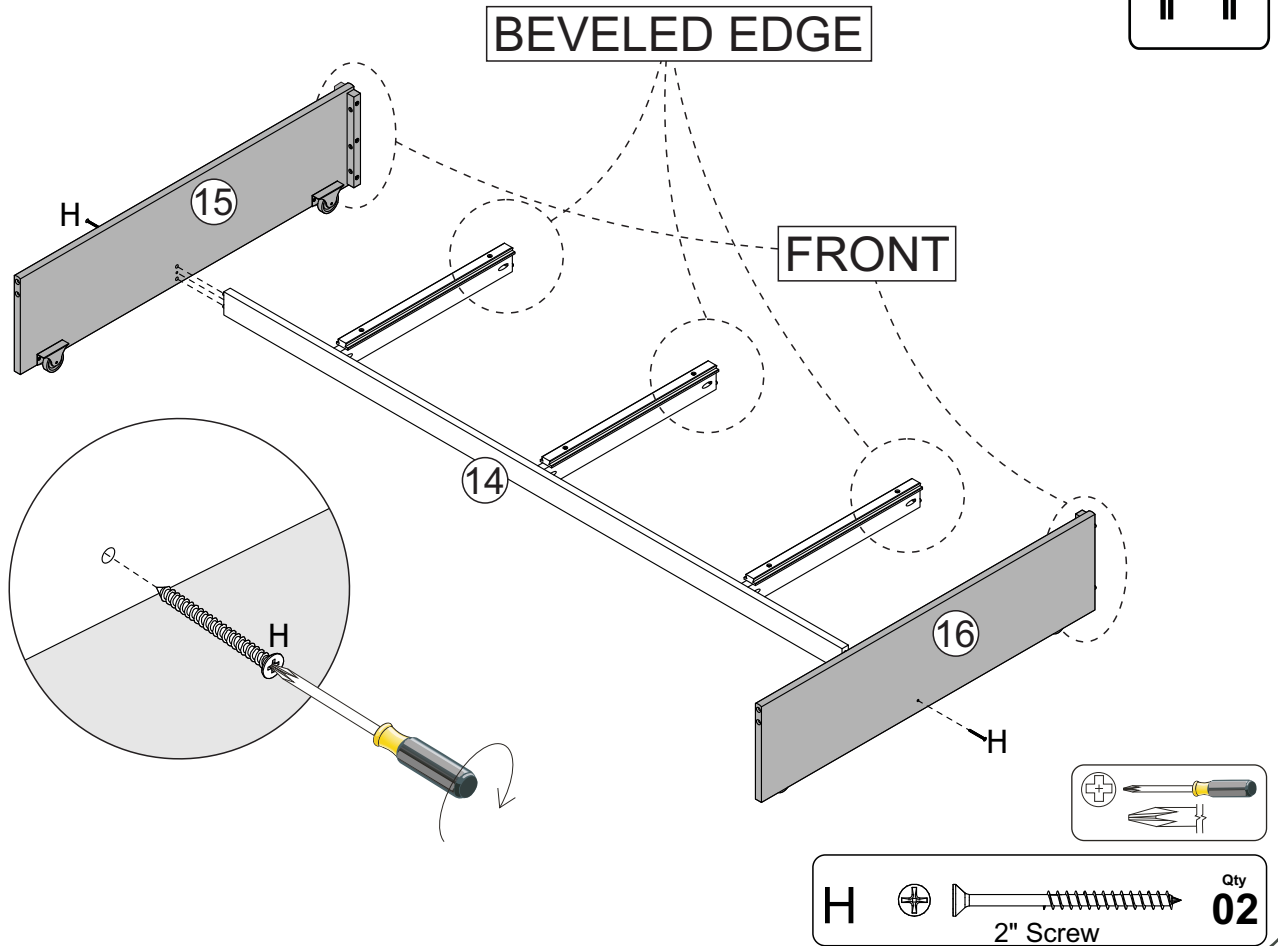
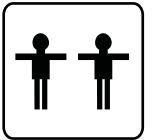

16

Attach the front of the trundle 17 to the sides 15, 16 and supports 12 using the screws (I).

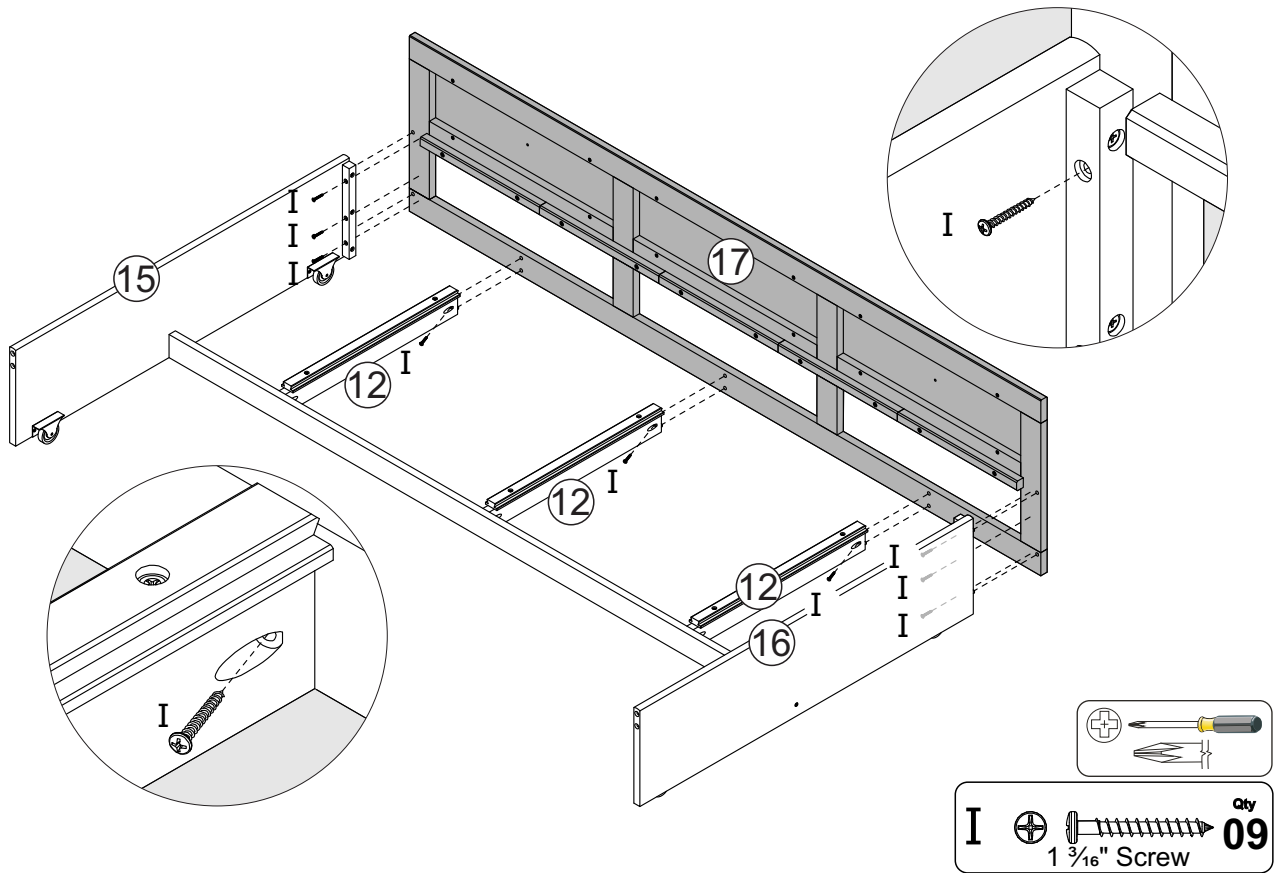
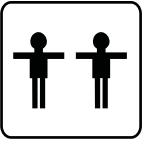

17

Attach the back panel 18 of the trundle to the sides 15 and 16 with bolts (F) using the allen wrench (O).

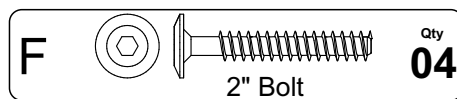
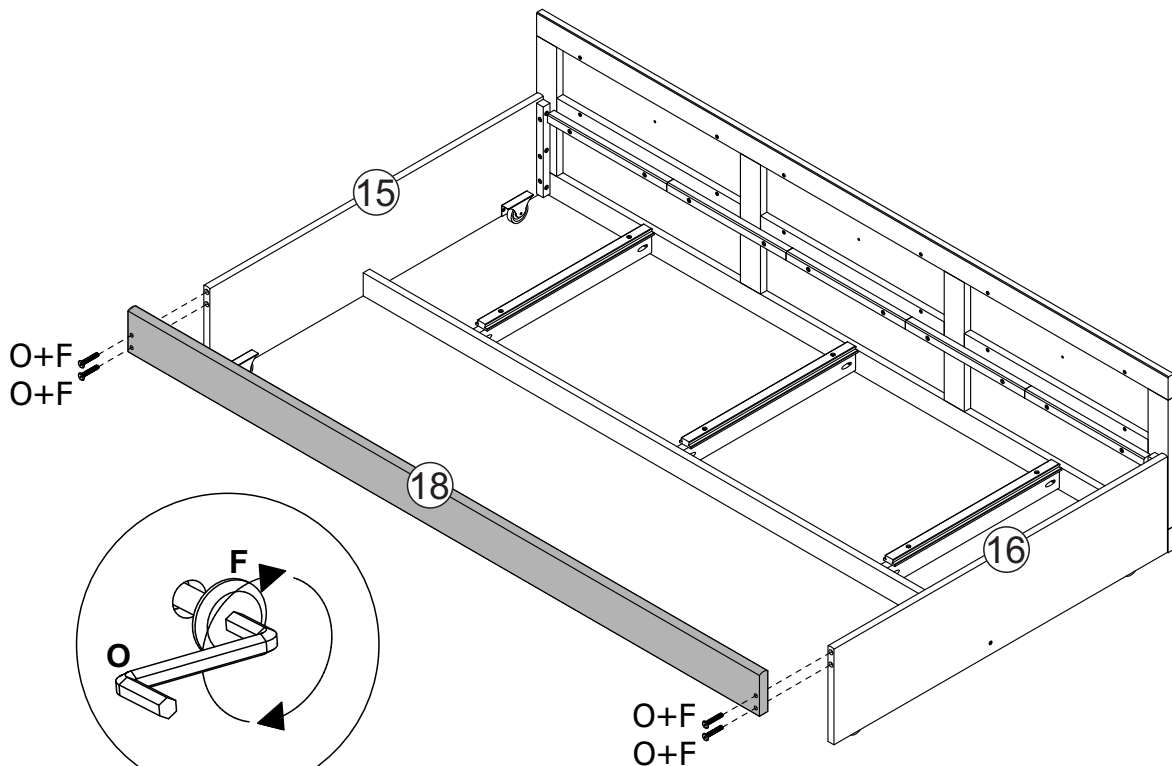
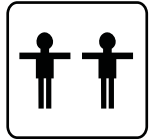

20

Drawers

(x3)

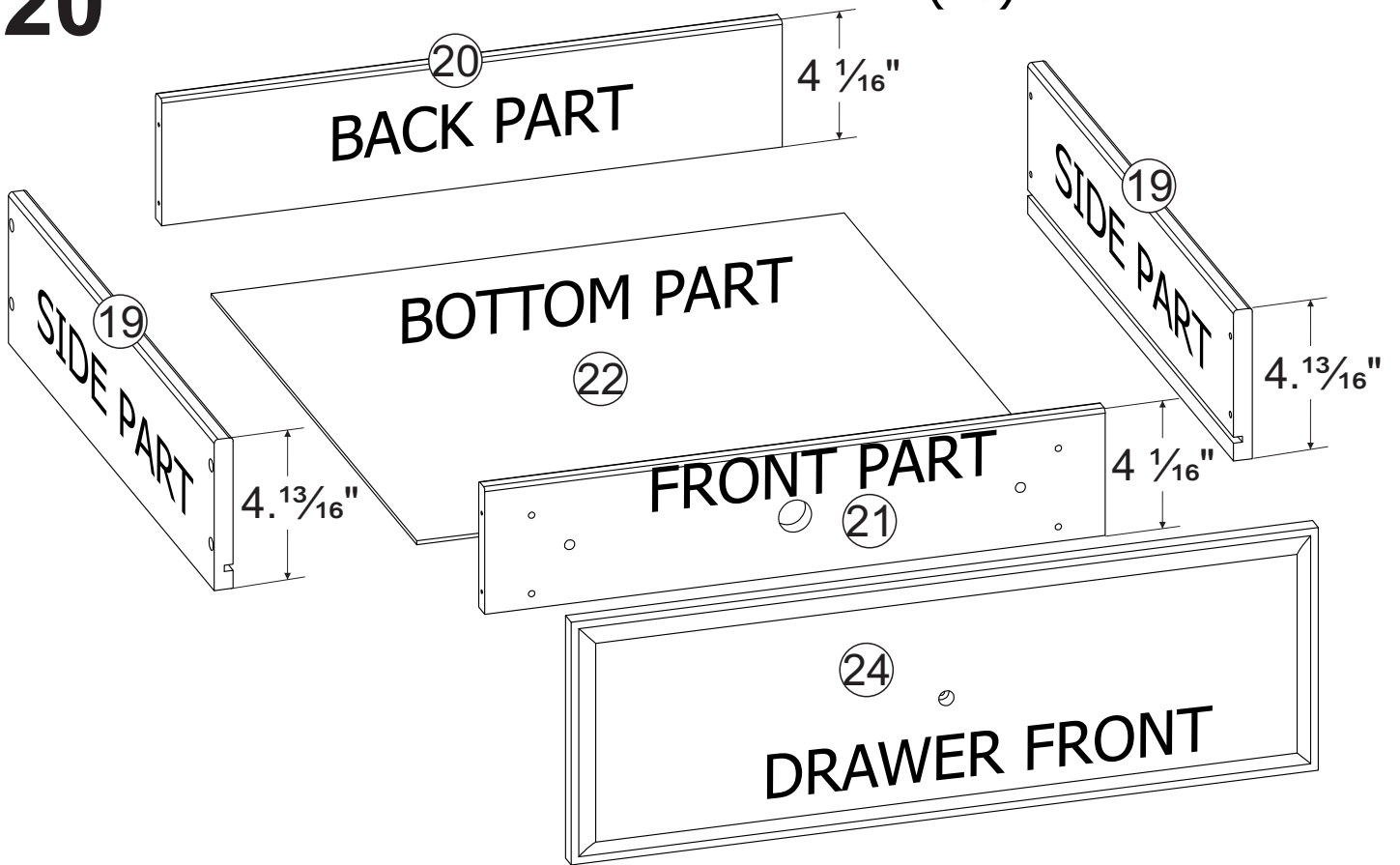

21

Attach the back part **20** to the side part **19** using the screws **(I)**. Align the base of the back part with the groove of the side part according to the detail.

(x3)

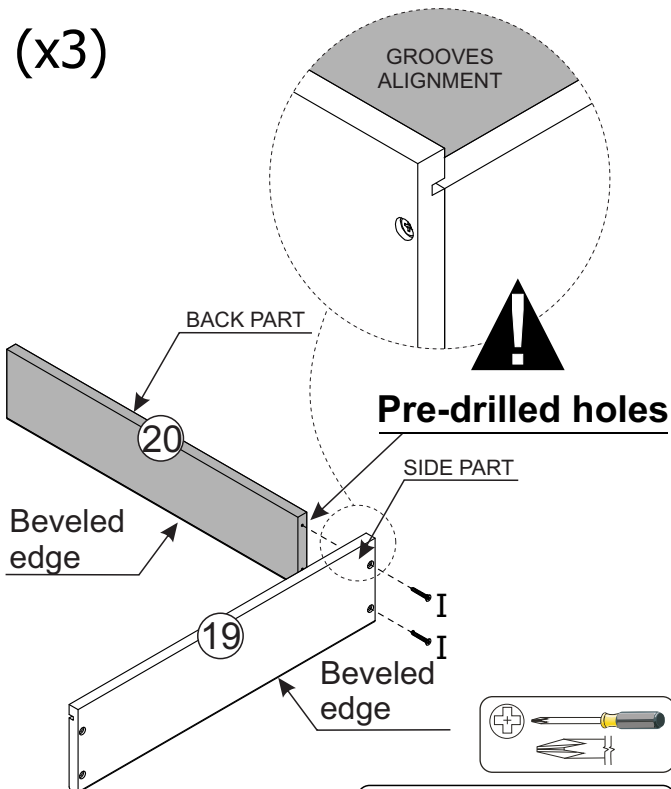

I Qty 06
1 3/16" Screw

22

Attach the front part **21** to the side part **19** using the screws **(I)**. Align the base of the front part with the groove of the side part according to the detail.

(x3)

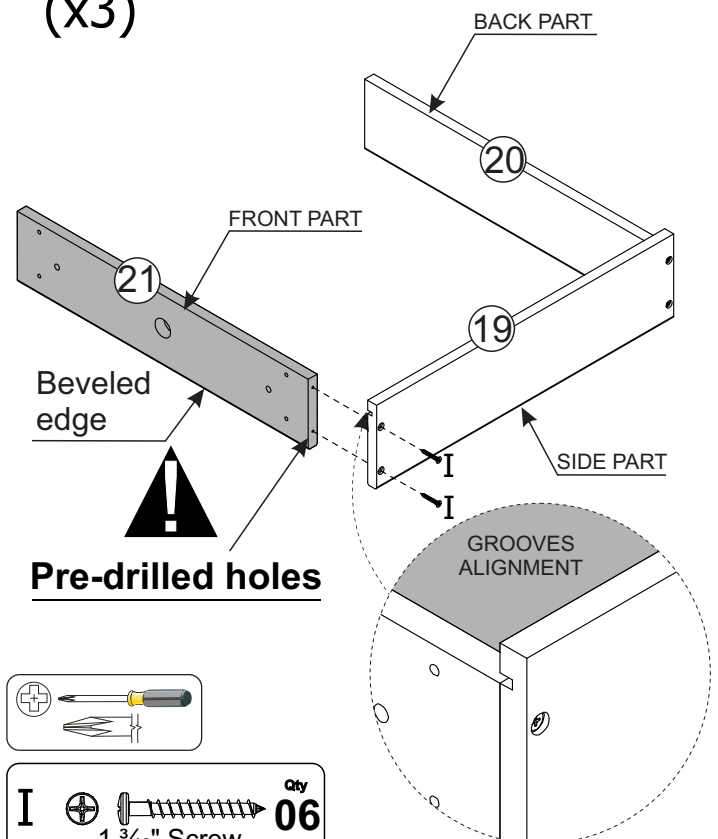

I Qty 06
1 3/16" Screw

29

(x3)

Insert the knobs **(N)** into the holes and attach with the screws **(I)**, as shown in the diagram.

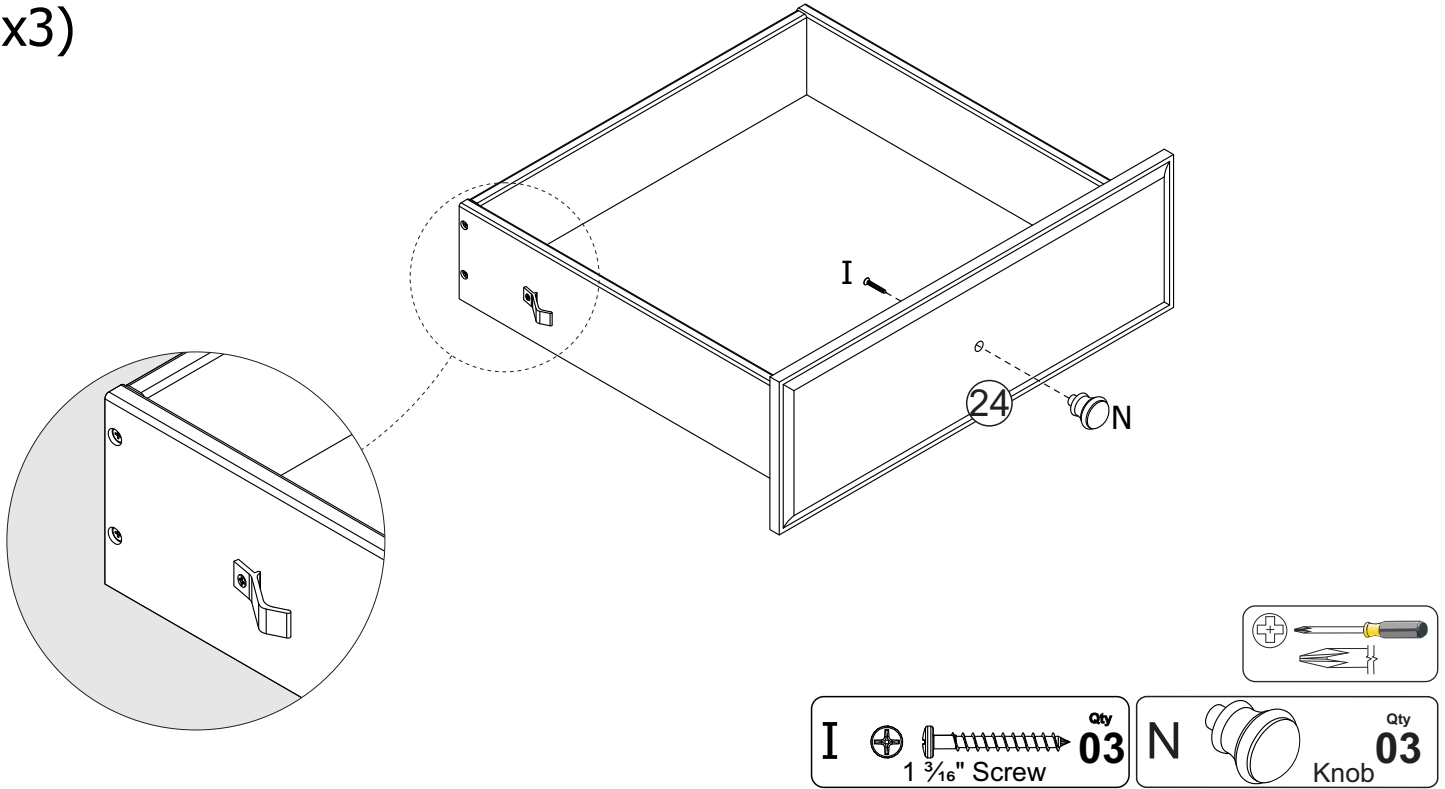

30

Attach one drawer at a time, fitting the slide to the center rail.

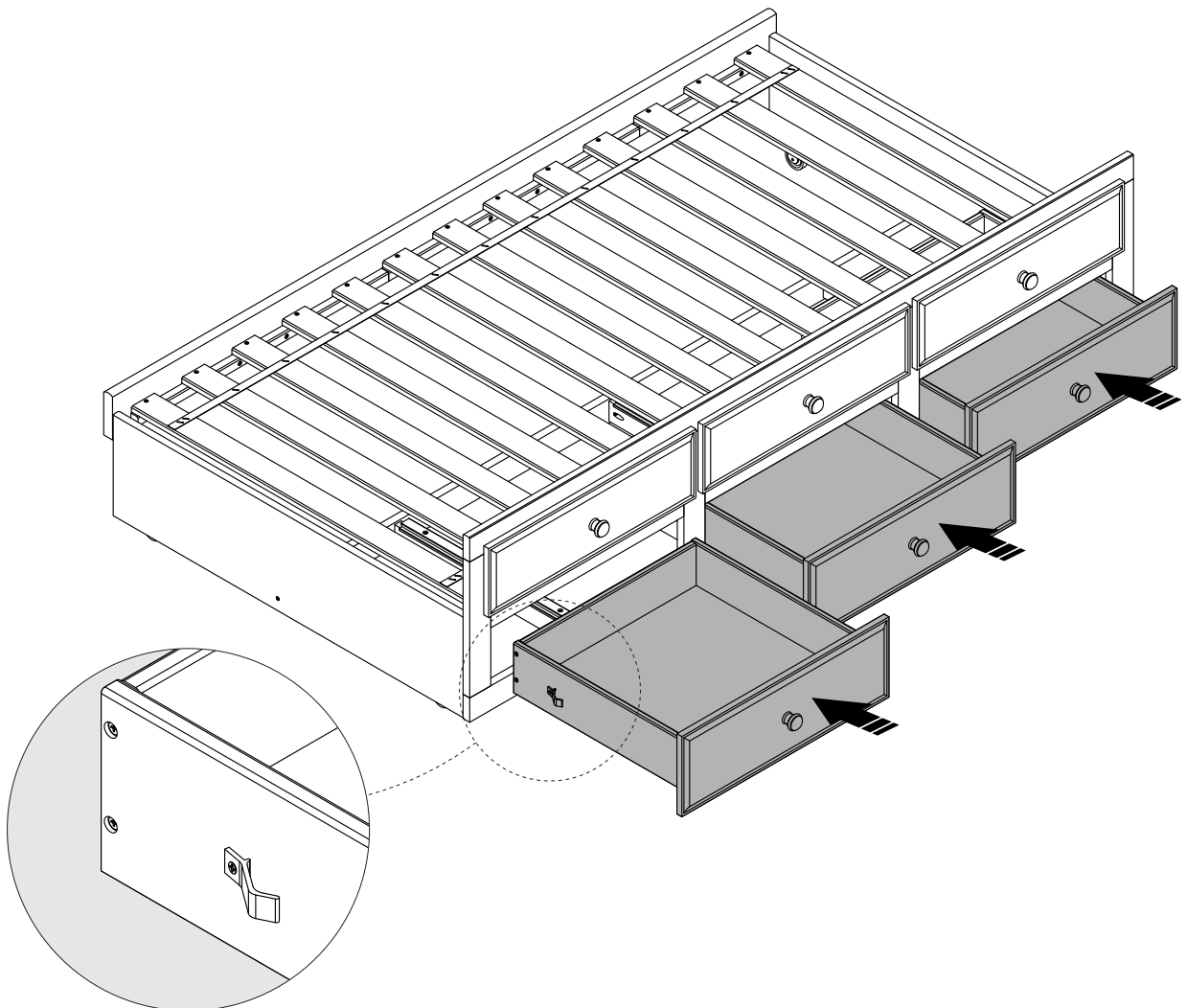

31

